

C3

Data Sheet

Safety precautions

Never stand in the immediate vicinity of loudspeakers driven at a high level. Professional loudspeaker systems are capable of causing a sound pressure level detrimental to human health. Seemingly non-critical sound levels (from approx. 95 dB SPL) can cause hearing damage if people are exposed to it over a long period.

In order to prevent accidents when deploying loudspeakers on the ground or when flown, please take note of the following:

When setting up the loudspeakers or loudspeaker stands, make sure they are standing on a firm surface. If you place several systems on top of one another, use straps to secure them against movement.

Only use accessories which have been tested and approved by d&b for assembly and mobile deployment. Pay attention to the correct application and maximum loading capacity of the accessories as specified in our "Rigging accessories" manual.

Ensure that all additional hardware, fixings and fasteners used for installation or mobile deployment are of an appropriate size and load safety factor. Pay attention to the manufacturers instructions and to the relevant safety guidelines.

Regularly check the loudspeaker housings and accessories for visible signs of wear and tear, and replace them when necessary.

Regularly check all load bearing bolts in the mounting devices.

Loudspeakers produce a static magnetic field even if they are not connected or are not in use. Therefore make sure when erecting and transporting loudspeakers that they are nowhere near equipment and objects which may be impaired or damaged by an external magnetic field. Generally speaking, a distance of 0.5 m (1.5 ft) from magnetic data carriers (floppy disks, audio and video tapes, bank cards, etc.) is sufficient; a distance of more than 1 m (3 ft) may be necessary with computer and video monitors.

WARNING!

CAUTION!

General Information

C3 Data Sheet

Version 2.0E, 05/2003, D2068.E.02

© by d&b audiotechnik AG 2003; all rights reserved.

The information presented in this document is, to the best of our knowledge, correct. We will however not be held responsible for the consequences of any errors or omissions.

Technical specifications, weights and dimensions should always be confirmed with d&b audiotechnik AG prior to inclusion in any additional documentation.

d&b audiotechnik AG
Eugen-Adolff-Strasse 134, D-71522 Backnang
Telephone +49-7191-9669-0, Fax +49-7191-95 00 00
E-mail: docadmin@dbaudio.com, Internet: www.dbaudio.com

C3

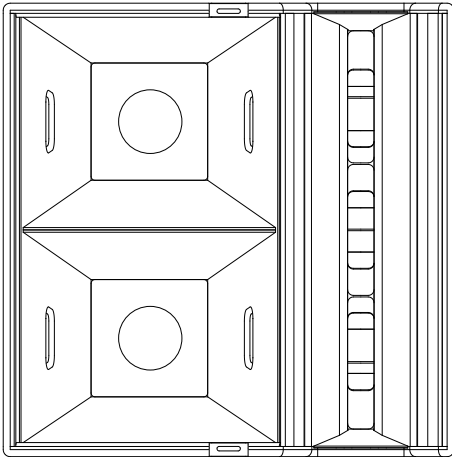

The C3 is the line array module for the d&b C4 system. The C3 cabinet houses 2 x 10" mid-range drivers and 3 x 1.3" HF compression drivers, producing a maximum sound pressure level greater than 143 dB SPL. The 2-way active C3 loudspeaker is an entirely hornloaded design which unlike other "line arrays" can be arrayed not only vertically but also horizontally, and by employing the distinctive 15° angled rear side panels and rigging accessories of the C4 cabinet it extends even further the scalability of the C4 system. Utilising an identical horizontal dispersion of 35° (above 900 Hz) and with a 5° vertical HF dispersion per cabinet, the C3 is used to build vertical columns producing a curved coherent wave front. This enables the C3 to address distances above 30 metres in different ways: starting as an extension module for a C4 array where additional mid and high range is required in the far field, up to a full line array approach using C4-TOP cabinets as near field supplements.

The C3 is designed for use with two or more cabinets in a vertical column and the use of single cabinets is therefore not recommended. The frequency response of two cabinets with a 5° vertical splay angle extends from 130 Hz to above 16 kHz in standard mode. With full range music program at high SPLs, additional subwoofers are required. The LFC mode extends the response for speech reproduction down to 80 Hz with reduced SPLmax. The C3 is designed to be flown in columns, which should be horizontally arrayed at 30° to each other. The vertical dispersion is designed for coupling angles of 1° to 5°, two C3s using the standard 23 link load chains (5° vertical splay) will give a vertical coverage of 10°. Utilizing an identical cabinet shape and rigging accessories as the C4, the C3 can be directly integrated into the C4 system.

The C3 cabinet is constructed from marine plywood, fitted with steel handles, MAN CF4 stud plate rigging points and has an impact resistant paint finish. The front of the mid-range section of the loudspeaker cabinet is protected by a rigid metal grill fitted with a replaceable acoustically transparent foam, and the HF section is fitted with a foam block in the horn throat. Catches are fitted to the top and bottom of the cabinet for securing an optional transport lid E7908. Mounted on the rear panel are ratchet strap guide plates (kelping bars), an EP5 or NL4 connector, two hinge plates, and four heavy duty wheels.

CAUTION!

Only operate C3 loudspeakers with a d&b P1200A mainframe fitted with a C3 controller module otherwise there is a risk of damaging the loudspeaker components.

	MF+	MF-	HF+	HF-	n.c.
EP5	1	2	3	4	5
NL4	1+	1-	2+	2-	

EP5 and NL4 pin assignments

Connections

The C3 cabinet can be fitted with either one EP5 male or one NL4 connector. Pin equivalents of EP5 and NL4 connectors are listed in the table on the left.

The C3 cabinet is a 2-way active design employing both channels of the P1200A power amplifier, fitted with the C3 controller module. Up to two C3 loudspeakers can be driven with one mainframe.

To avoid HF loss with long cable runs each cabinet must be connected to one of the mainframe outputs using separate cables with a minimum conductor size of 4 x 2.5 mm² (13 AWG).



C3 controller module switches

HFC switch and indicator

Selecting the HFC mode (High Frequency Compensation, yellow HFC LED illuminated), compensates for loss of high frequency energy due to absorption in air. The HFC switch should be used exclusively for those cabinets covering the very far field. This guarantees the correct sound balance between close and remote audience areas, whilst the mainframes driving the array can be fed with the same signal.

LFC switch and indicator

In LFC mode (Low Frequency Compensation, yellow LFC LED illuminated), the low frequency response is extended down to 80 Hz for speech reinforcement without subwoofers.

Indicators

These indicators give a three stage indication of the C3 controller signal levels.

- **ISP** (**I**nput **S**ignal **P**resent, green) illuminates when the input signal of the controller input exceeds a -36 dBu threshold value. The ISP circuit is unaffected by the setting of the controller mute switch and level control.
- **GR** (**G**ain **R**eduction, yellow) illuminates when the controller limiter reduces gain by more than 3 dB.
- **OV** (**O**verload red) illuminates when the controller limiter reduces gain by more than 12 dB or overload occurs in the signal path (input signal too high) or when the amplifier gain is reduced because the output current is too high (e.g. due to a short circuit).

The limiter indicators show the condition of the HF and LF channels independently.

Level Control

The detented level control adjusts the controller input sensitivity and has a 18 dB range (-12 dB ... $+6$ dB) calibrated in 1 dB steps. The controls are normally set to 0 dB.

Arraying C3 and C4 cabinets

Vertical array of C3 cabinets

A vertical array of C3 cabinets produces a precisely shaped wavefront following the mechanical arrangement of the cabinets. The cut off at the upper and lower limits of the vertical dispersion of a C3 column is very sharp, and therefore precise aiming is absolutely essential to address the desired audience area.

The vertical coverage angle of a single cabinet is 5° and this defines the maximum splay angle between adjacent cabinets in a column. This dispersion angle is achieved above approximately 5 kHz, while lower frequencies will disperse into a wider area creating an overlap of the coverage patterns of the single cabinets. Therefore directivity and the level of lower frequencies increases with every cabinet added to the column. Two cabinets arrayed vertically with a 5° splay angle produce a flat frequency response. Longer columns will therefore boost low and low/mid frequencies according to the graph on the right.

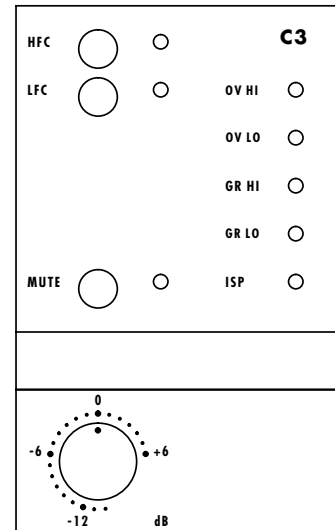

C3 controller module

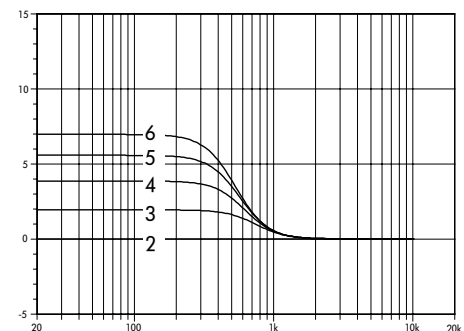

Typical change in frequency response with increasing column length (2, 3, 4, 5 and 6 deep)

Longest C3 column in array	Low shelf f_c	Gain dB
3	800 Hz	-3
4	600 Hz	-4
5	450 Hz	-5
6	350 Hz	-6
7	250 Hz	-7
8	200 Hz	-8

Single column

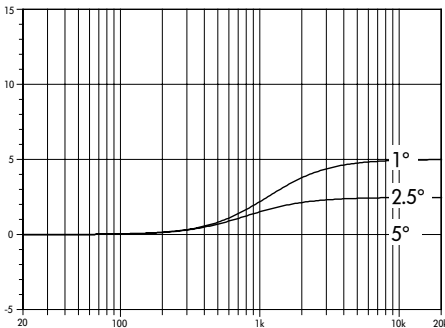

Typical change in frequency response when decreasing the splay angle between two cabinets from 5° to 2.5° and 1°.

This typical behaviour can be compensated by using a standard 2nd order (12 dB) low shelf filter. The corner frequency and gain setting depend on the number of C3 cabinets in the longest column and on the overall array size. Typical corner frequencies are listed in the table on the left; the gain listed applies to a single column. This equalization has to be used for the C3s only. C4-TOP cabinets in the array should be driven from a separate signal.

Decreasing the splay angle to 2.5° or even 1° will also create an overlap of the coverage patterns above 5 kHz resulting in increased high frequency output to the main axis. This effect can be used to compensate for air absorption effects when covering remote audience areas. In opposite to the HFC circuit of the controller this "mechanical HFC" equalization does not affect the headroom of the system.

To achieve a smooth level distribution the vertical splay of a column is the first thing to consider when designing a set up for a specific venue. Usually the distances to the audience that an array has to cover increase from the bottom to the top of a column, consequently more power is required at the top. This can be achieved by using different vertical splay angles between cabinets in a column, with smaller angles achieving more power within a given vertical segment. For a smooth level distribution over distance it is desirable to gradually change the angle increments, e.g. 1°, 2.5°, 5° for a 4 deep column.

Vertical array of C3 and C4 cabinets

As their horizontal dispersion behaviour is identical, C4-TOP and C3 cabinets can be easily combined in one array. The larger vertical dispersion of a C4-TOP can be used efficiently to cover the near field in front of a C3 column. A vertical splay of 5° or 10° to the lowest C3 is useful, depending on the total height of the system.

Horizontal array of C3 and C4 cabinets

The horizontal angle between adjacent C3 and/or C4 cabinets in an array can be set to between 20° and 30°. The most even and widest energy distribution is achieved with 30°. Smaller angles between the cabinets will give a smaller horizontal coverage area but will produce higher sound pressure on the centre axis of the array.

The configuration of any array should be thoroughly adapted to the actual venue room acoustics and requirements. In order to keep diffuse sound low, the total coverage angle should only be as wide as necessary to cover the audience area.

Operation with C4-SUB and B2-SUB

To extend the C3 frequency response C4-SUBs should be used. Forming columns of SUB cabinets improves efficiency and vertical directivity at low frequencies.

For a balanced sound at high levels a ratio of at least one C4-SUB per C3 or C4-TOP cabinet is required.

For a further extension of bandwidth and headroom ground stacked B2 subwoofers are used (INFRA mode).

Time alignment and signal distribution

When combining C3s and C4-TOPs the correct time alignment of both systems is of great importance. To achieve this C3 and C4-TOPs have to be driven by separate input signals. With a delay of 0.3 ms in the C4 signal path both systems are perfectly coherent over the whole audio band, while the C3 signal path contains the vertical array equalization as described above. To avoid the influence of different latencies (inherent delays) of the signal chains, make sure that the C3s and C4s in one array are driven with the same signal processing devices using different outputs.

Normally C4-SUBs will be driven from the same signal processor output as the C4-TOPs, or if B2-SUBs are used, from the C4-OUT of the B2 controller. Should the B2-SUBs be driven separately (e.g. when driven from an auxiliary output of the console or for time alignment reasons), the low cut provided by the C4-OUT of the B2 controller can also be created for the C4 using a standard parametric bandpass filter in a signal processor. The parameters are $f = 44 \text{ Hz}$, $Q = 3$, $\text{Gain} = -6 \text{ dB}$.

Integration into the C4 flying system

The vertical splays between the cabinets of a C3/C4 array are set by load chains of different lengths. d&b offer chains for 1° , 2.5° and 5° angles plus a shortening chain enabling greater variable angles. For a coherent coupling of adjacent cabinets the precise alignment of the rear panels of the cabinets is essential. Therefore it is necessary to use the d&b Z5110.100 Hinge between the cabinets throughout the whole column.

C3 arrays have a very high vertical directivity, therefore the use of a precise digital angle finder to verify the desired aiming is strongly recommended. Deviations of less than 1° can have an immense impact on the coverage in the far field. A laser distance finder is recommended to set the correct array height.

d&b **TransCalc V3** is a Microsoft Excel based calculation tool for planning the mechanical set up of the d&b Transformer flying system. It computes all settings for the flying system plus dimensions, weights, CAD export and a parts list for the whole rig. Version 3 now provides a graphic display for up to four listening planes in 2D projections showing the aiming points of all C3 and C4-TOP cabinets of the array. The above mentioned laser distance finder is a useful tool to assess the dimensions of the listening areas.

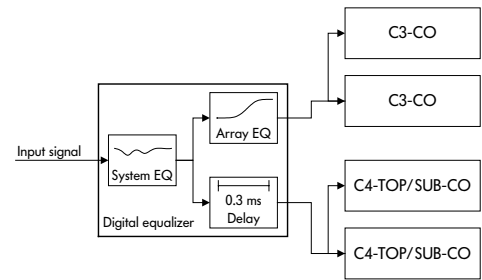

C3 wiring with C4-TOP and C4-SUB

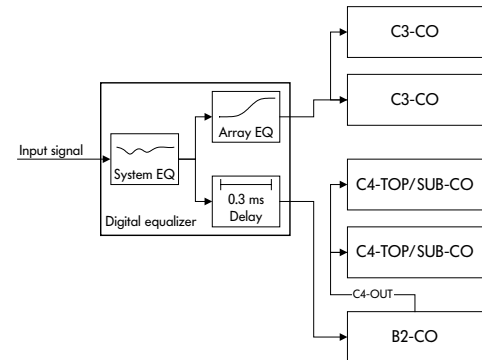

C3 wiring with C4-TOP, C4-SUB and B2-SUB

Dispersion characteristics

The diagram below shows dispersion angle vs frequency, plotted using lines of equal sound pressure (isobars) at -6 dB and -12 dB. The nominal horizontal dispersion of 35° is maintained above 900 Hz.

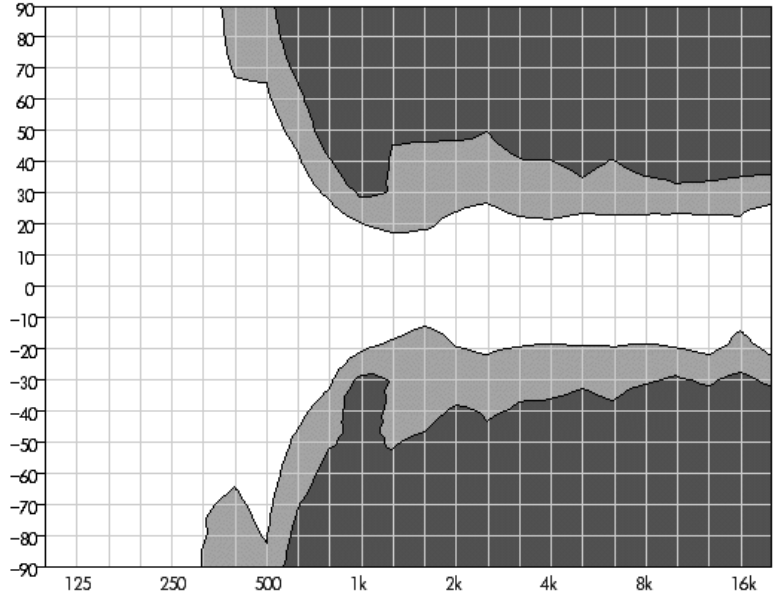

C3 horizontal isobar diagram

Example set up

The example below shows a C3/C4 set up arranged to provide the coverage and level distribution for a simple rectangular audience area. The central C3 column projects energy to the far field with a 40° horizontal coverage angle, the C4-TOP cabinets lower down in the cluster provide the wider horizontal coverage angle required in the near field. The C3s in the inner column cover the mid-field and the mixing position, while the column of C4-SUBs maintains a consistent vertical directivity in the lower frequencies.

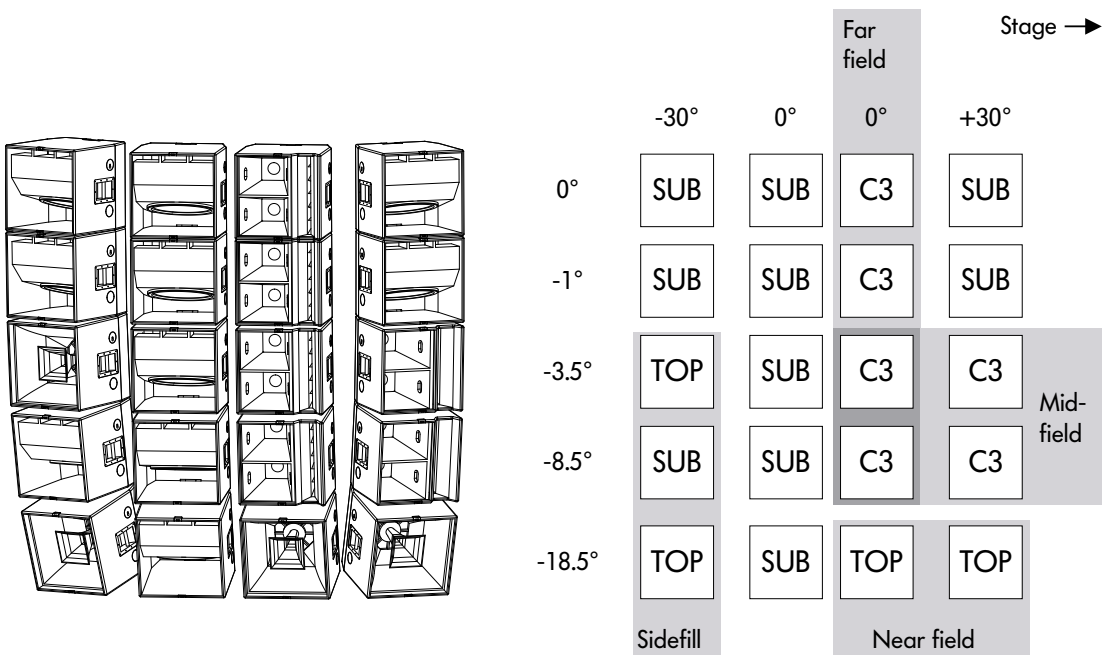

Technical specifications

C3 system data

Frequency response (-5 dB standard, two cabinets) 130 Hz ... 16 kHz
 Frequency response (-5 dB LFC Mode, two cabinets) 80 Hz ... 16 kHz
 Max. sound pressure (1 m, free field) > 143 dB
 (SPLmax peak, pink noise test signal with crest factor of 4)
 Polarity to controller INPUT (XLR pin 2: +/3: -) LF: +/HF: +

C3 loudspeaker

Nominal impedance (LF/HF) 4 ohms/5.3 ohms
 Power handling capacity LF (RMS / peak 10 ms) 500/2000 W
 Power handling capacity HF (RMS / peak 10 ms) 150/600 W
 Nominal dispersion angle (hor. x vert.) 35° x 5°
 Connections 1 x EP5
 (optional 1 x NL4)
 Pin assignments EP5: 1/2 LF; 3/4 HF
 NL4: 1+/1- LF; 2+/2- HF
 Weight 71 kg (156 lb)

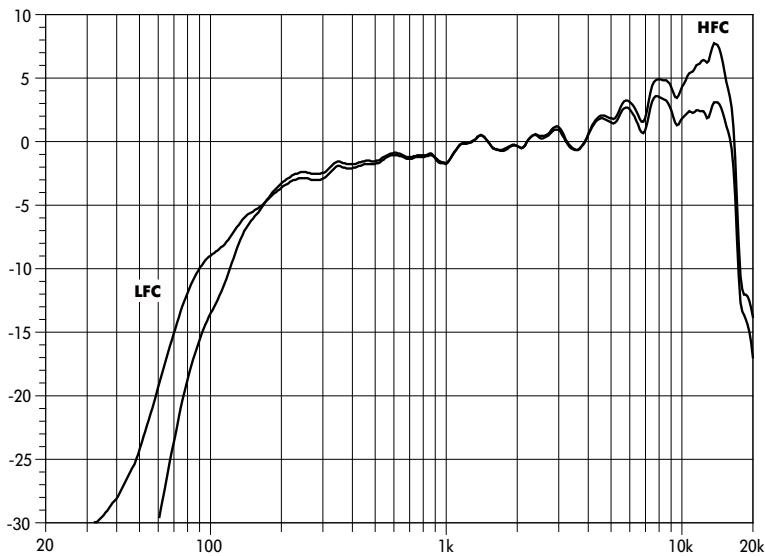

C3 frequency response, standard, LFC and HFC mode (single cabinet)

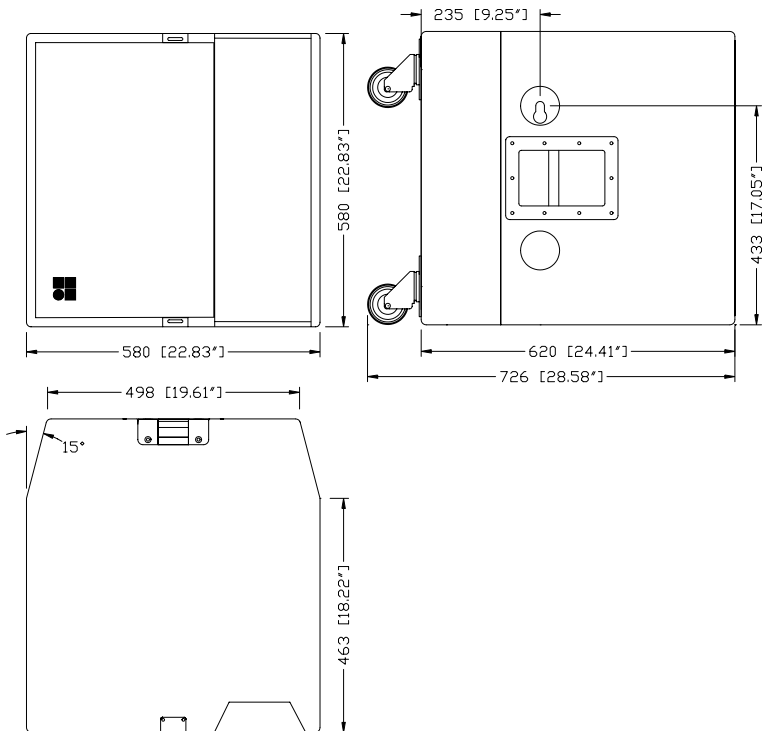

C3 cabinet dimensions in mm [inch]

