

E3

Data Sheet

Safety precautions

Never stand in the immediate vicinity of loudspeakers driven at a high level. Professional loudspeaker systems are capable of causing a sound pressure level detrimental to human health. Seemingly non-critical sound levels (from approx. 95 dB SPL) can cause hearing damage if people are exposed to it over a long period.

In order to prevent accidents when deploying loudspeakers on the ground or when flown, please take note of the following:

When setting up the loudspeakers or loudspeaker stands, make sure they are standing on a firm surface. If you place several systems on top of one another, use straps to secure them against movement.

Only use accessories which have been tested and approved by d&b for assembly and mobile deployment. Pay attention to the correct application and maximum loading capacity of the accessories as specified in our "Rigging accessories" manual.

Ensure that all additional hardware, fixings and fasteners used for installation or mobile deployment are of an appropriate size and load safety factor. Pay attention to the manufacturers instructions and to the relevant safety guidelines.

Regularly check the loudspeaker housings and accessories for visible signs of wear and tear, and replace them when necessary.

Regularly check all load bearing bolts in the mounting devices.

Loudspeakers produce a static magnetic field even if they are not connected or are not in use. Therefore make sure when erecting and transporting loudspeakers that they are nowhere near equipment and objects which may be impaired or damaged by an external magnetic field. Generally speaking, a distance of 0.5 m (1.5 ft) from magnetic data carriers (floppy disks, audio and video tapes, bank cards, etc.) is sufficient; a distance of more than 1 m (3 ft) may be necessary with computer and video monitors.

WARNING!

CAUTION!

General Information

E3 Data Sheet

Version 2.0 E, 05/2001, D2072.E.02

© by d&b audiotechnik AG 2001; all rights reserved.

The information presented in this document is, to the best of our knowledge, correct. We will however not be held responsible for the consequences of any errors or omissions.

Technical specifications, weights and dimensions should always be confirmed with d&b audiotechnik AG prior to inclusion in any additional documentation.

d&b audiotechnik AG

Eugen-Adolff-Strasse 134, D-71522 Backnang

Telephone +49-7191-9669-0, Fax +49-7191-95 00 00

E3

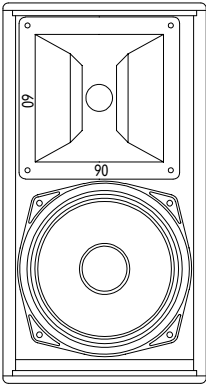

The E3 cabinet is a full range, two way bass-reflex enclosure. Fitted with a single 6.5" LF driver passively connected to a 1" HF compression driver coupled to a constant directivity horn with a 90° x 60° dispersion. Illustrated in the drawing on the left is an E3 with the standard 90° horizontal horn configuration. The horn can be rotated through 90° for a reversed 60° x 90° (h x v) dispersion.

The E3 cabinet is constructed from marine plywood with an impact resistant paint finish. The front of the loudspeaker cabinet is fitted with a rigid metal grill covered with a replaceable acoustically transparent foam. A connector plate with two parallel wired Speakon connectors, which can be swapped between the rear and side of the cabinet, together with pairs of M8 threaded inserts for mounting brackets on each panel allow the E3 to be mounted in almost any position.

The outstanding feature of the E3 is its neutral sound balance coupled with an extraordinarily high output capability for a cabinet of such a size. The E3 frequency response covers a 80 Hz to 17 kHz band making it extremely versatile and ideal for use in near field, delay, effects, ultra compact monitor and miniature array systems. Used with an auxiliary subwoofer system, the E3 can also easily reproduce high level music programs. Suitable subwoofers are E12-SUB, E18-SUB or C7-SUB.

With an asymmetrical cabinet design and an extensive range of mounting and rigging accessories (please refer to the E-Series brochure) E3 cabinets can be mounted or flown almost anywhere and used in pairs to create 120° or 180° horizontal arrays.

CAUTION!

Only operate E3 loudspeakers with a d&b P1200A mainframe fitted with E3 controller modules or a d&b E-PAC in E3 configuration, otherwise there is a risk of damaging the loudspeaker components.

Altering the HF horn dispersion

The E3 HF horn has a square flange allowing it to rotate through 90°. Two dispersion angles, 90° and 60°, are engraved on the flange, the value on the horizontal edge indicates the loudspeakers horizontal dispersion angle.

To change the horn dispersion, first remove the front grill by undoing the Allen screws (M4x25 mm) at the top and bottom of the grill using a 2.5 mm Allen key. Using a 3 mm Allen key, undo the 4 Allen screws (M4x25 mm) which hold the horn in place. The horn can then be rotated through 90°, refastened and the front grill replaced.

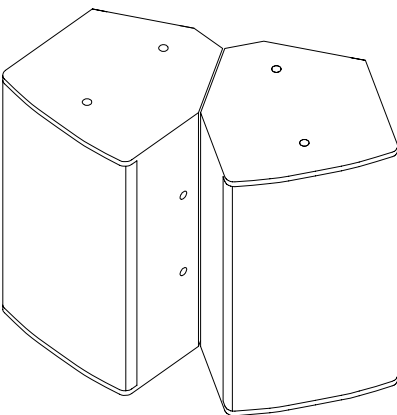

E3 array, 120° coverage

Connections

The E3 cabinet is fitted with a pair of Speakon-NL4 connectors. All four pins of both connectors are wired in parallel. The E3 uses the pin assignments 1+/1-. Pins 2+/2- are designated to active d&b subwoofers. Using one connector as the input, the second connector allows for direct connection to additional loudspeakers.

The connector plate is fitted to the E3 rear panel. Next to it, on the left hand side panel, is a metal blank plate with the cabinet details and serial number. The connector and blank plates can be swapped over to allow mounting brackets to be fitted to the back panel of the cabinet or to allow it to be placed on its back as a stage monitor.

The plates are removed by undoing the four 2.5 mm hex head screws securing each panel. The connector wiring is disconnected in order to swap the panels. Make sure when reconnecting the wiring that the red wire goes to pin 1+ and the black wire to pin 1- on the Speakon connector board.

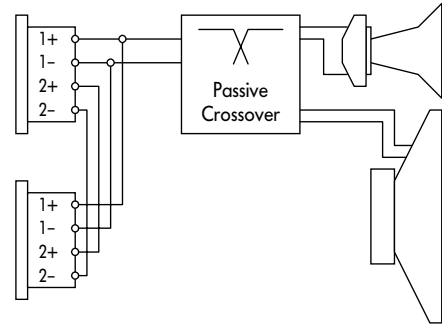

Connector wiring

IMPORTANT!

Operation with P1200A

Up to four E3 loudspeakers can be driven by each P1200A power amplifier channel. Fitting one E3-CO and one subwoofer controller module allows a single mainframe to drive four E3 and two active subwoofer cabinets (E18-SUB or C7-SUB). All cabinets can be linked together locally and fed by a single four-wire cable from either mainframe output connector.

E3 controller module switches

CUT switch and indicator

Set to CUT, a high pass filter with a 110 Hz cut-off frequency is inserted in the controller signal path. The yellow CUT LED illuminates. The E3 system is now configured for use with d&b C or E-Series active subwoofers.

HFA switch and indicator

In HFA mode (High Frequency Attenuation), the HF response of the E3 system is rolled off. The yellow HFA LED illuminates. The HFA circuit configures the E3 loudspeakers to provide a natural, balanced frequency response when a unit is placed close to listeners in near field or delay use.

High Frequency Attenuation begins gradually at 1 kHz, dropping by approximately 3 dB at 10 kHz. This roll off mimics the decline in frequency response experienced when listening to a system from a distance in a typically reverberant room or auditorium.

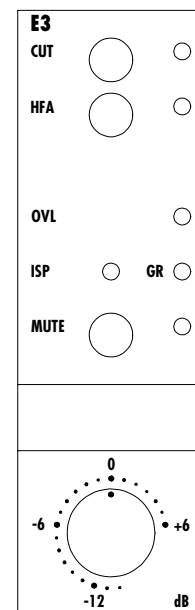

Controls on E3 controller module

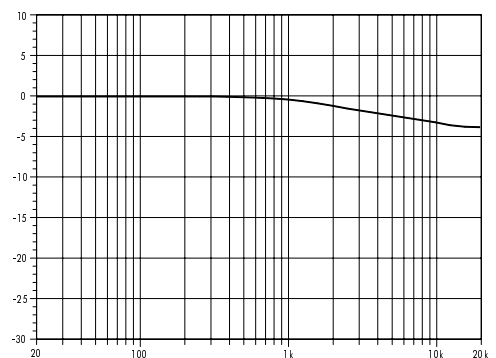

Frequency response correction of HFA circuit

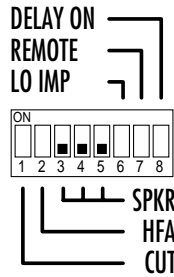
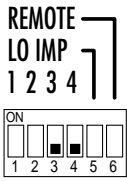

E-PAC version 1

E-PAC version 2

E-PAC Configuration for E3

Operation with E-PAC

To drive E3 cabinets the E-PAC has to be configured to E3 mode.

For an E-PAC version 1 and 2, the configuration is selected by setting the appropriate DIP switches on the rear panel.

For an E-PAC version 3, the configuration is set via a front panel digital rotary encoder in conjunction with an LCD.

The CUT and HFA settings are available on versions 2 and 3. The characteristics of the CUT and HFA settings are explained on the previous page under the section "E3 controller module switches".

The E-PAC can drive up to two E3 cabinet at an output power of 300 watts. LO IMP mode allows the E-PAC to drive four E3 cabinets with a 6 dB reduction of input level to the speakers.

Dispersion characteristics

The diagrams below show dispersion angle vs frequency plotted using lines of equal sound pressure (isobars) at -6 dB and -12 dB.

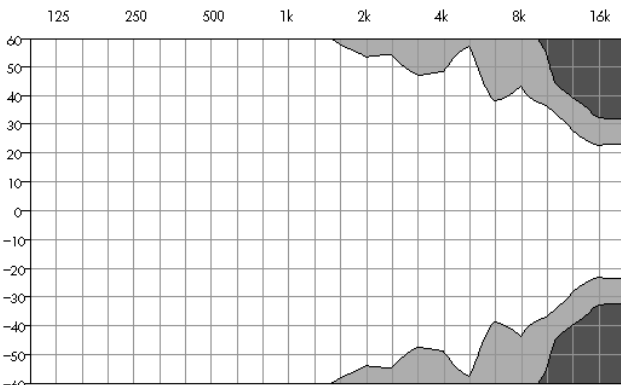

horizontal

E3 isobar diagram, configuration 90° horizontal (standard)

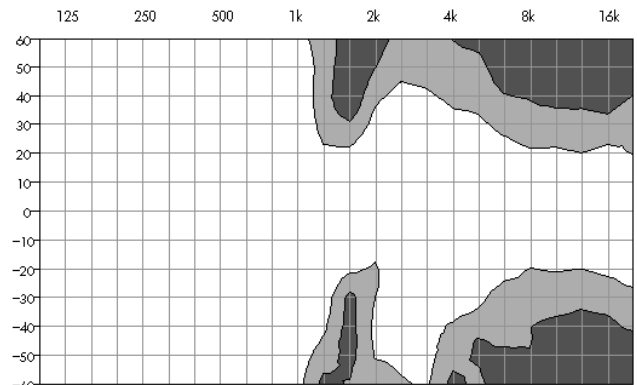

vertical

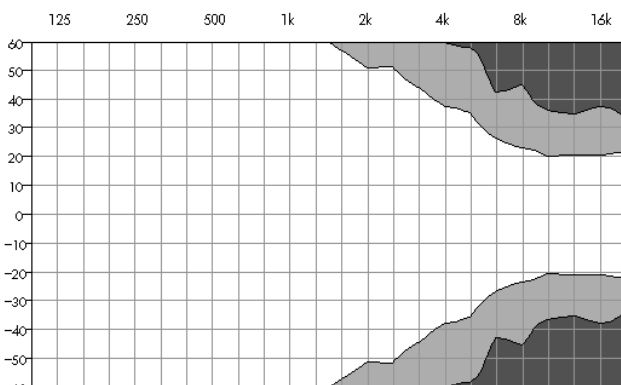

horizontal

E3 isobar diagram, configuration 90° vertical

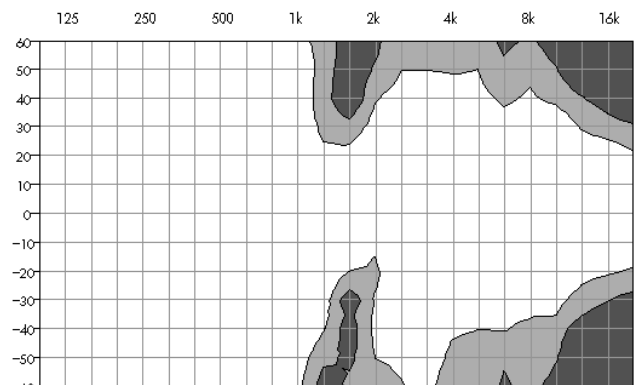

vertical

Technical specifications

E3 system data

Frequency response (-5 dB)	80 Hz ... 18 kHz
Max. sound pressure (1 m, free field)	122 dB
(SPLmax peak, pink noise test signal with crest factor of 4)	
Input level (SPLmax)	+9 dBu
Input level (100 dB-SPL / 1 m)	-10 dBu
Polarity to controller INPUT (XLR pin 2: + / 3: -)	LF: + / HF: -

E3 loudspeaker

Nominal impedance	16 ohms
Power handling capacity (RMS / peak 10 ms)	120 / 480 W
Nominal dispersion angle (hor. x vert.)	90° x 60°
..... (rotatable through 60° x 90°)	
Connections	2 x Speakon-NL4
Pin assignments	1+ / 1-
Weight	7.2 kg (16 lb)

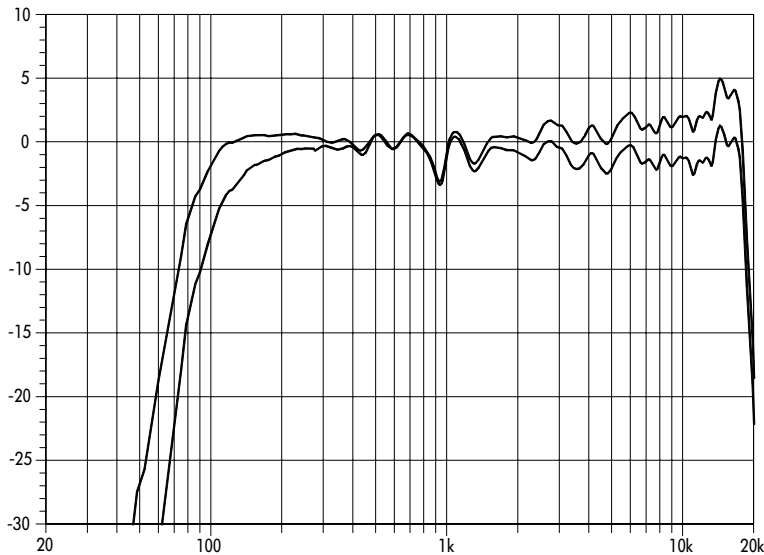

E3 frequency response, standard, CUT and HFA switch settings

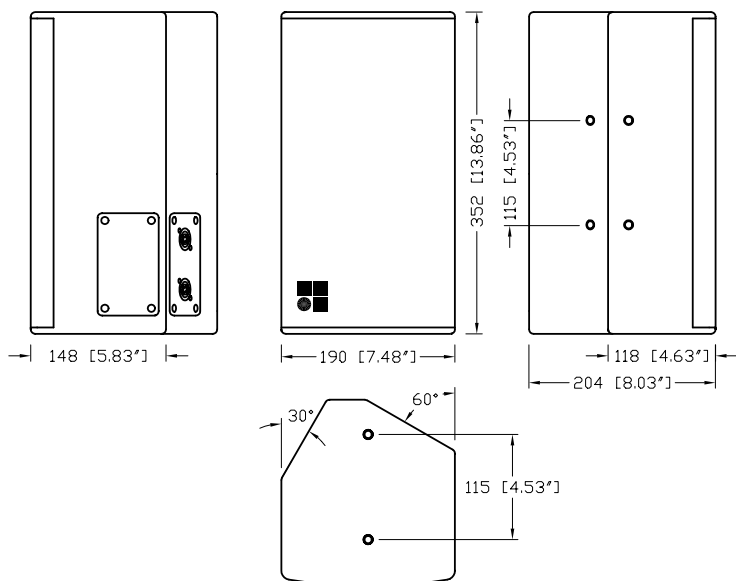

E3 cabinet dimensions in mm [inch]

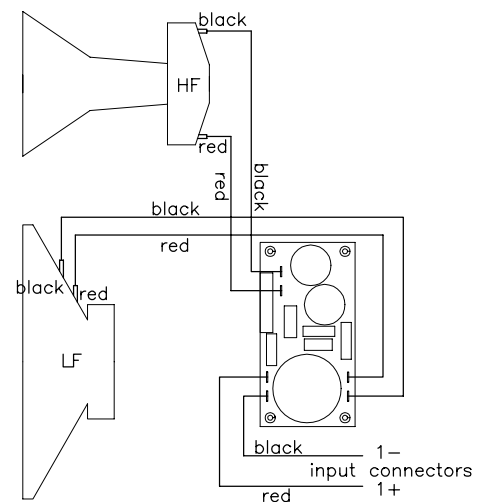

E3 wiring diagram

