

C7-TOP

Data Sheet

Safety precautions

Never stand in the immediate vicinity of loudspeakers driven at a high level. Professional loudspeaker systems are capable of causing a sound pressure level detrimental to human health. Seemingly non-critical sound levels (from approx. 95 dB SPL) can cause hearing damage if people are exposed to it over a long period.

In order to prevent accidents when deploying loudspeakers on the ground or when flown, please take note of the following:

When setting up the loudspeakers or loudspeaker stands, make sure they are standing on a firm surface. If you place several systems on top of one another, use straps to secure them against movement.

Only use accessories which have been tested and approved by d&b for assembly and mobile deployment. Pay attention to the correct application and maximum loading capacity of the accessories as specified in our "Rigging accessories" manual.

Ensure that all additional hardware, fixings and fasteners used for installation or mobile deployment are of an appropriate size and load safety factor. Pay attention to the manufacturers instructions and to the relevant safety guidelines.

Regularly check the loudspeaker housings and accessories for visible signs of wear and tear, and replace them when necessary.

Regularly check all load bearing bolts in the mounting devices.

Loudspeakers produce a static magnetic field even if they are not connected or are not in use. Therefore make sure when erecting and transporting loudspeakers that they are nowhere near equipment and objects which may be impaired or damaged by an external magnetic field. Generally speaking, a distance of 0.5 m (1.5 ft) from magnetic data carriers (floppy disks, audio and video tapes, bank cards, etc.) is sufficient; a distance of more than 1 m (3 ft) may be necessary with computer and video monitors.

WARNING!

CAUTION!

General Information

C7-TOP Data Sheet

Version 2.0E, 05/2001, D2079.E.02

© by d&b audiotechnik AG 2001; all rights reserved.

The information presented in this document is, to the best of our knowledge, correct. We will however not be held responsible for the consequences of any errors or omissions.

Technical specifications, weights and dimensions should always be confirmed with d&b audiotechnik AG prior to inclusion in any additional documentation.

d&b audiotechnik AG

Eugen-Adolff-Strasse 134, D-71522 Backnang

Telephone +49-7191-9669-0, Fax +49-7191-95 00 00

C7-TOP

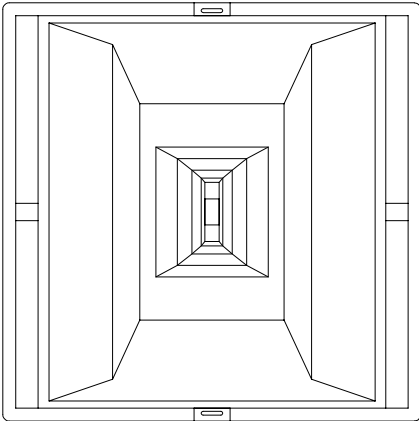

The C7-TOP is a two way horn loaded loudspeaker which provides full range coverage at very high SPLs. The constant directivity design of the coaxial horns used in the C7-TOP helps maintain the 75° x 40° dispersion down to 600Hz. Two passively coupled drivers are used - a 15" low/mid driver back loaded by a vented enclosure, and a 1.5" exit HF compression driver.

The C7-TOP cabinet is constructed from marine plywood, fitted with steel handles, MAN CF4 stud plate rigging points and has an impact resistant paint finish. The front of the loudspeaker cabinet is protected by a rigid metal grill, covered with a replaceable acoustically transparent foam and fitted with catches to the top and bottom for securing an optional transport lid E7908. Mounted on the rear panel are ratchet strap guide plates (kelping bars), four M10 threaded inserts for attaching installation hardware, two Speakon NL4 or EP-5 connectors wired in parallel and four heavy duty wheels.

As the C7-TOP maintains its high efficiency from 18 kHz down to 68 Hz, subwoofers are not needed for applications which do not require very low frequencies.

When high level bass reproduction is desired, then the C7-TOP can be supplemented with the C7-SUB or B2-SUB systems. In larger systems the C7-TOP can also be operated with the C4-SUB and B2 subwoofer combination.

High output, wide horizontal and narrow vertical dispersion down to the low/mid range means that a simple set up using a pair of C7-TOP cabinets, one per side, can deliver smooth wide area coverage across the near field to a distance of 30 m (100 ft). Within a larger set up C7-TOP cabinets are ideal as frontfill, nearfill or delay systems for C4 arrays.

The C7-TOP is compatible with the C4 System - both loudspeaker systems share similar phase responses and cabinet dimensions allowing the straightforward construction of stacked or flown mixed cabinet arrays.

Placing a pair of C7-TOP cabinets with their angled rear side panels together sets them 50° apart to give a combined horizontal coverage of 130°. Similarly a C7-TOP deployed with a C4-TOP sets the cabinets 40° apart to give a combined horizontal coverage of 100°.

CAUTION!

Only operate C7-TOP loudspeakers with a d&b P1200A mainframe fitted with C7-TOP controller modules, otherwise there is a risk of damaging the loudspeaker components.

Connections

The C7-TOP cabinet is fitted with a pair of Speakon-NL4 connectors. All four pins of both connectors are wired in parallel. The C7-TOP uses the pin assignments 1+/1-. Pins 2+/2- are designated to d&b C and E-Series active subwoofers. Using one connector as the input, the second connector allows for direct connection to additional loudspeakers.

The C7-TOP can be supplied with EP-5 output connectors as an option. Pin equivalents of Speakon-NL4 and EP-5 connectors are listed in the table on the right.

Up to two C7-TOP loudspeakers can be driven by each P1200A power amplifier channel. Fitting one C7-TOP-CO and one subwoofer controller module allows a single mainframe to drive two C7-TOP's and two active subwoofer cabinets (C7-SUB or C4-SUB). All cabinets can be linked together locally and fed by a single four-wire cable from either mainframe output connector.

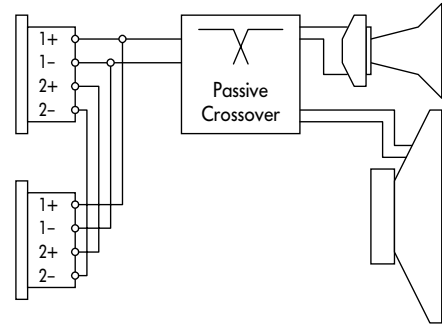

connector wiring

EP-5	1	2	3	4	5
NL4	1+	1-	2+	2-	n.c.

Speakon- NL4 and EP-5 pin assignments

C7-TOP controller module switches

CUT switch & indicator

Set to CUT, a high pass filter with a 130 Hz cutoff frequency is inserted in the controller signal path. The yellow CUT LED illuminates. The C7 system is now configured for use either with d&b C-Series active subwoofers or the B2 subwoofer set to 'standard' mode.

For high level music applications with the C7-SUB or C4-SUB, we recommend a ratio of two subwoofers per C7-TOP cabinet.

When C7-TOP's are flown without additional subwoofers the cabinets should be operated full range, i.e. CUT mode not selected on the controller module. Low end support can then be provided by C7-SUB systems in 100Hz mode or a B2 system in INFRA mode. A single B2-SUB is enough to support two C7-TOP cabinets. The low crossover frequency allows the subwoofers to be placed centrally and to be driven with a mono signal.

HFA switch & indicator

In HFA mode (High Frequency Attenuation), the HF response of the C7 system is rolled off. The yellow HFA LED illuminates. The HFA circuit configures the C7-TOP to provide a natural, balanced frequency response at close listening positions.

High Frequency Attenuation begins gradually at 1 kHz, dropping to approximately 3 dB down at 10 kHz. This roll off mimics the decline in frequency response experienced when listening to a system from a distance in a typically reverberant room or auditorium.

The HFA facility thus provides an easy way to adapt C7-TOP loudspeakers for use close to an audience, for example as nearfills or delays.

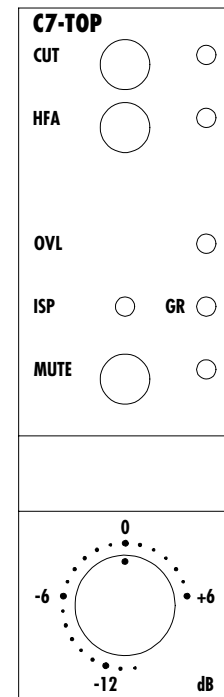

Controls on C7-TOP controller module

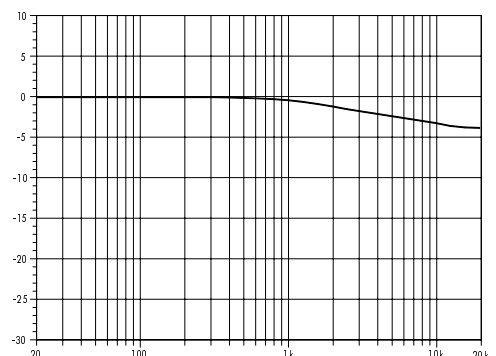

Frequency response correction of HFA circuit

Operation with E-PAC (only possible with E-PAC version 3 with display)

To drive C7-TOP cabinets the E-PAC has to be configured to C7-TOP mode.

For an E-PAC version 3, the configuration is set via a front panel digital rotary encoder in conjunction with an LCD.

The CUT and HFA settings are available. The characteristics of the CUT and HFA settings are explained on the previous page under the section "C7-TOP controller module switches".

The E-PAC can drive a single C7-TOP cabinet at an output power of 300 watts. LO IMP mode allows the E-PAC to drive two C7-TOP cabinets with a 6 dB reduction of input level to the speakers.

Dispersion characteristics

The diagrams below show dispersion angle vs frequency plotted using lines of equal sound pressure (isobars) at -6 dB and -12 dB. The nominal 75° horizontal dispersion is maintained from 17 kHz down to 600 Hz.

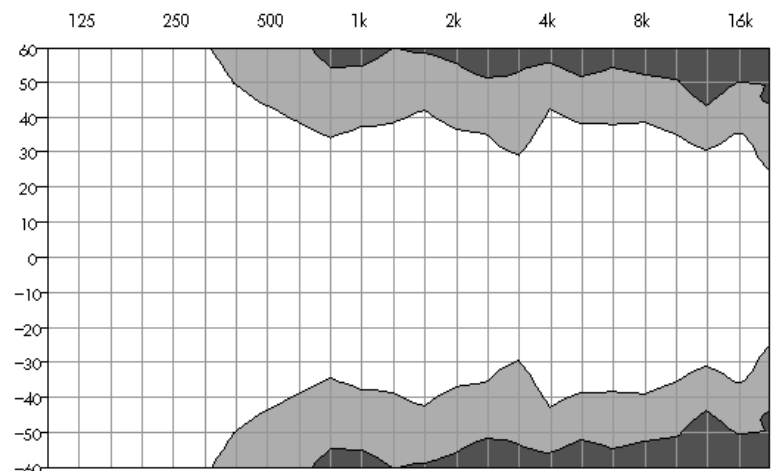

horizontal

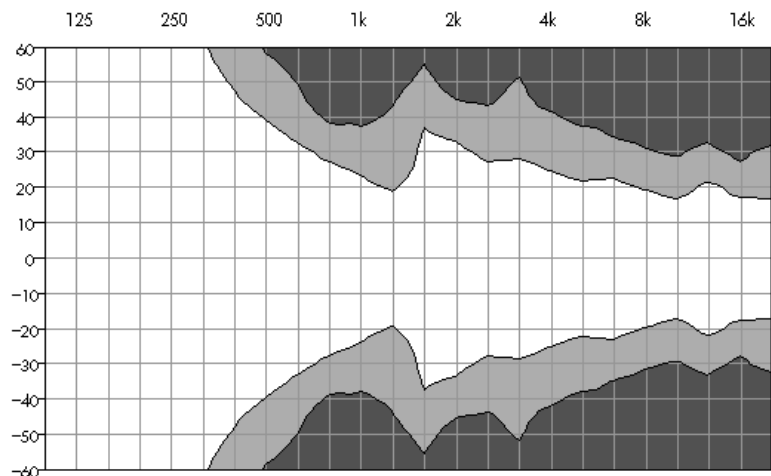

vertical

C7-TOP isobar diagram

Technical specifications

C7 system data

Frequency response (-5 dB)	68 Hz ... 18 kHz
Max. sound pressure (1 m, free field) with P1200A	136 dB
Max. sound pressure (1 m, free field) with E-PAC	134 dB
(SPLmax peak, pink noise test signal with crest factor of 4)	
Input level (SPLmax)	+14 dBu
Input level (100 dB-SPL / 1 m)	-19 dBu
Polarity to controller INPUT (XLR pin 2: + / 3: -)	LF: + / HF: +

C7 loudspeaker

Nominal impedance	8 ohms
Power handling capacity (RMS / peak 10 ms)	200 / 800 W
Nominal dispersion angle (hor. x vert.)	75° x 40°
Connections	2 x Speakon-NL4
.....	(optional 2 x EP-5)
Pin assignments	1+ / 1-
.....	(EP-5: 1 / 2)
Weight	52 kg (115 lb)

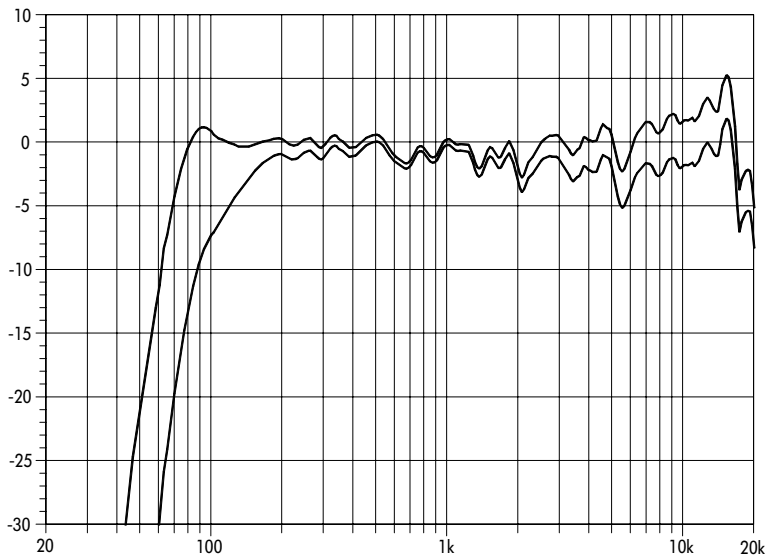

C7-TOP frequency response, standard, CUT and HFA switch settings

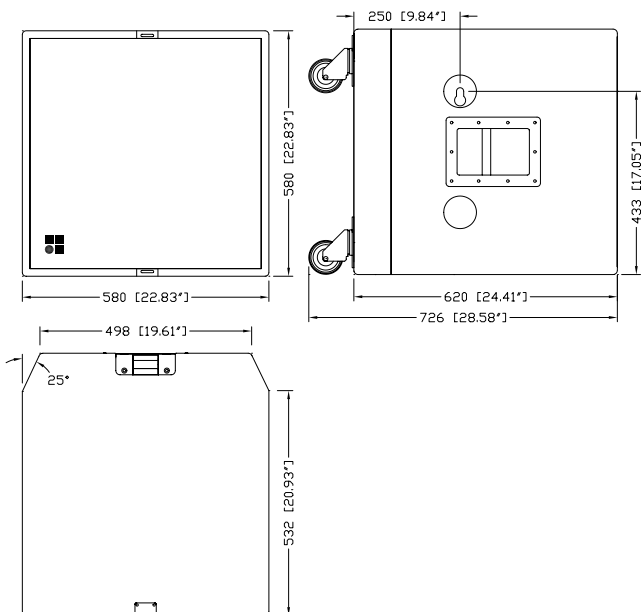

C7-TOP cabinet dimensions in mm [inch]

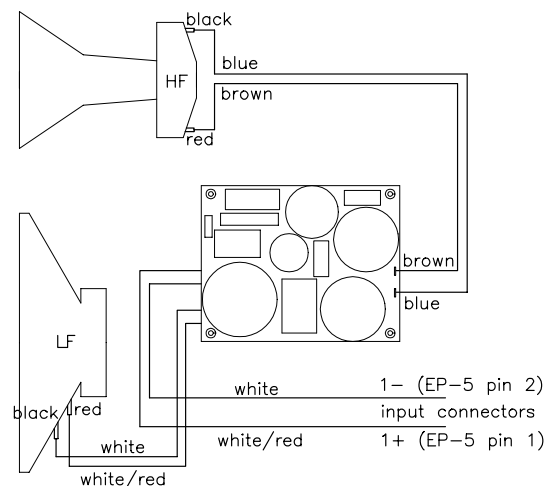

C7-TOP wiring diagram

