

C4-SUB

Data Sheet

Safety precautions

Never stand in the immediate vicinity of loudspeakers driven at a high level. Professional loudspeaker systems are capable of causing a sound pressure level detrimental to human health. Seemingly non-critical sound levels (from approx. 95 dB SPL) can cause hearing damage if people are exposed to it over a long period.

In order to prevent accidents when deploying loudspeakers on the ground or when flown, please take note of the following:

When setting up the loudspeakers or loudspeaker stands, make sure they are standing on a firm surface. If you place several systems on top of one another, use straps to secure them against movement.

Only use accessories which have been tested and approved by d&b for assembly and mobile deployment. Pay attention to the correct application and maximum loading capacity of the accessories as specified in our "Rigging accessories" manual.

Ensure that all additional hardware, fixings and fasteners used for installation or mobile deployment are of an appropriate size and load safety factor. Pay attention to the manufacturers instructions and to the relevant safety guidelines.

Regularly check the loudspeaker housings and accessories for visible signs of wear and tear, and replace them when necessary.

Regularly check all load bearing bolts in the mounting devices.

Loudspeakers produce a static magnetic field even if they are not connected or are not in use. Therefore make sure when erecting and transporting loudspeakers that they are nowhere near equipment and objects which may be impaired or damaged by an external magnetic field. Generally speaking, a distance of 0.5 m (1.5 ft) from magnetic data carriers (floppy disks, audio and video tapes, bank cards, etc.) is sufficient; a distance of more than 1 m (3 ft) may be necessary with computer and video monitors.

WARNING!

CAUTION!

General Information

C4-SUB Data Sheet

Version 2.0E, 05/2001, D2075.E.02

© by d&b audiotechnik AG 2001; all rights reserved.

The information presented in this document is, to the best of our knowledge, correct. We will however not be held responsible for the consequences of any errors or omissions.

Technical specifications, weights and dimensions should always be confirmed with d&b audiotechnik AG prior to inclusion in any additional documentation.

d&b audiotechnik AG

Eugen-Adolff-Strasse 134, D-71522 Backnang

Telephone +49-7191-9669-0, Fax +49-7191-95 00 00

C4-SUB

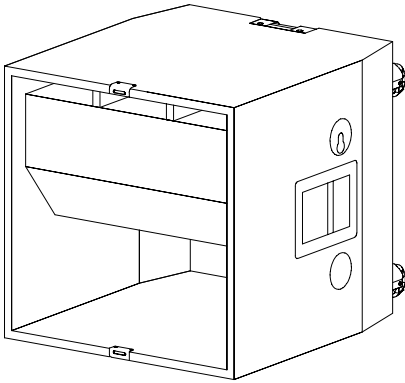

The C4-SUB is a compact, horn-loaded bandpass design employing a single 18" driver. It is designed for use with the C4-TOP cabinet as a part of the C4 System.

The C4-SUB cabinet is constructed from marine plywood, fitted with steel handles, MAN CF4 stud plate rigging points and has an impact resistant paint finish. The front of the loudspeaker cabinet is protected by a rigid metal grill, covered with a replaceable acoustically transparent foam and fitted with catches to the top and bottom for securing an optional transport lid E7908. Mounted on the rear panel are ratchet strap guide plates (kelping bars), four M10 threaded inserts for attaching installation hardware, two Speakon NL4 or EP-5 connectors wired in parallel and four heavy duty wheels.

Designed to be actively driven using the d&b P1200A mainframe, the C4-SUB is normally used to support the C4-TOP cabinet by covering the 50 Hz to 150 Hz frequency band.

The C4-SUB cabinet has the same dimensions and shape as the C4-TOP and is also fitted with the same hardware so that arrays, ground-stacked or flown, using different combinations of these cabinets can be speedily built and deployed.

However, the C4-SUB can also be used with other d&b C-Series and F-Series systems. This is particularly important when these systems require flown subwoofers.

Only operate C4-SUB loudspeakers with a d&b P1200A mainframe fitted with C4-SUB controller modules otherwise there is a risk of damaging the loudspeaker components.

CAUTION!

Connections

The C4-SUB cabinet is fitted with a pair of Speakon-NL4 connectors. All four pins of both connectors are wired in parallel. The C4-SUB uses the pin assignments 2+/2-. Pins 1+/1- are designated to d&b C- and E-Series full range systems. Using one connector as the input, the second connector allows for direct connection to additional loudspeakers.

The C4-SUB can be supplied with EP-5 output connectors as an option. Pin equivalents of Speakon-NL4 and EP-5 connectors are listed in the table below.

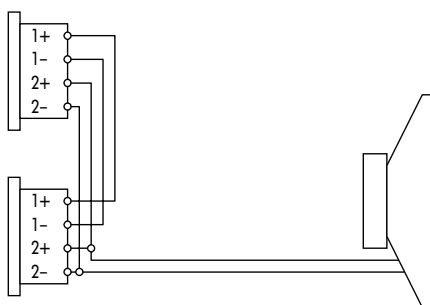

Connector wiring

EP-5	1	2	3	4	5
NL4	1+	1-	2+	2-	n.c.

Speakon- NL4 and EP-5 pin assignments

Operation with P1200A

Up to two C4-SUB's can be driven by each P1200A power amplifier channel. Fitting one C4-SUB-CO and one C-Series TOP controller module allows a single mainframe to drive two C4-SUB and two mid/high cabinets. All cabinets can be linked together locally and fed by a single four-wire cable from either mainframe output connector.

Operation with E-PAC (only possible with E-PAC version 3 with display)

To drive C4-SUB cabinets the E-PAC has to be configured to C4-SUB mode.

For an E-PAC version 3, the configuration is set via a front panel digital rotary encoder in conjunction with an LCD.

The E-PAC can drive a single C4-SUB cabinet at an output power of 300 watts. We do not recommend that two C4-SUB cabinets are driven in LO IMP mode as the 6 dB reduction in input level to the loudspeakers results in no gain in acoustical output.

Stacking notes

The horn chamber, which transmits frequencies ranging from approx. 70 Hz to 180 Hz, is located in the bottom half of the cabinet. A reflex system which covers frequencies below this range (tuning frequency: 53 Hz) is located at the top of the front panel. The system has been tuned to ensure the correct operation of C4-SUB used on its own. When arraying C4-SUB's there is therefore no point in creating an enlarged horn opening by stacking the cabinets horn to horn.

If the C4-SUB system is placed directly on the floor, we advise turning the cabinet upside down so that floor coupling helps to increase the effective baffle area for the reflex port. If C4-SUB systems are stacked two high, the upper C4-SUB can be turned upside down so that both reflex ports lie directly on top of each other. If cabinets are stacked three or more high they can be used in their upright positions - with their reflex ports to the top.

Combination of C4-SUB and B2 systems

The C4-SUB operates down to 50 Hz (-5 dB). However, some applications require frequencies below this cutoff. Using the B2 subwoofer can not only give the required LF extension but also increase the low frequency headroom of the C4 system.

Setting the B2 controller module to INFRA by a front panel switch configures the B2 system to operate in the 50 Hz area covering a one octave band from 32 Hz to 68 Hz (-5 dB).

A single B2 system delivers enough low end bass to supplement the output of four C4-SUB cabinets. When C4-SUB and B2-SUB's are operated in an identical acoustic environment (e.g. in one cluster on the ground), with controllers set to the same level, the combined systems low frequency limit is 37 Hz (-5 dB).

The system headroom can be increased in applications using less than four C4-SUB's to one B2 subwoofer by raising the lower cut off frequency of the C4-SUB's. A dedicated balanced output (C4-OUT) is provided on the rear panel of the B2 controller for driving the C4 system under these conditions.

The C4-OUT introduces a relatively narrow-band signal attenuation around 50 Hz, which raises the lower frequency limit of the C4-SUB's to around 60 Hz. This shift is not acoustically critical since the region affected is covered by the B2 system. The response of the TOP cabinets in the system will remain the same whether their controllers (C4-TOP-CO or C7-TOP-CO) are fed directly or by the C4-OUT signal.

In applications where most of the C4-SUB's are flown, they are deprived of the additional acoustic gain due to ground coupling. To maintain a tight bass sound the level of the ground stacked B2-SUB's should be turned down respectively. (approx. -6 dB). The increased system headroom derived from the use of the C4-OUT can be an advantage when used to drive the flown system.

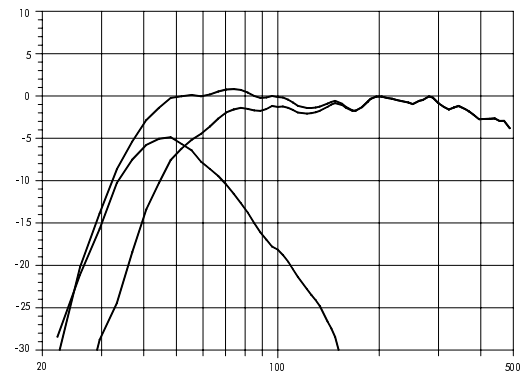

C4 and B2-SUB systems, 4:1 ratio

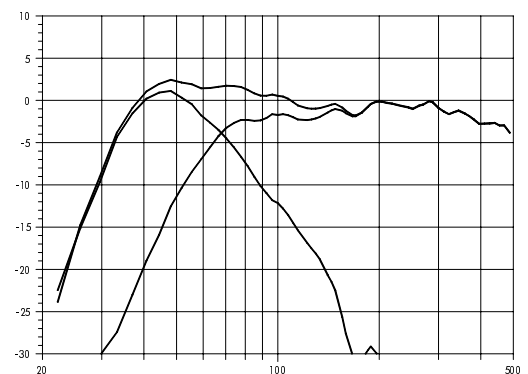

C4 and B2-SUB systems driven from C4-OUT connection, 2:1 ratio

Technical specifications

C4-SUB system data

Frequency response (-5 dB).....	50 Hz ... 150 Hz
Max. sound pressure (1 m, free field) with P1200A	133 dB
Max. sound pressure (1 m, free field) with E-PAC	131 dB
(SPLmax peak, pink noise test signal with crest factor of 4)	
Input level (SPLmax).....	+17 dBu
Input level (100 dB-SPL / 1 m).....	-13 dBu
Polarity to controller INPUT (XLR pin 2: + / 3: -)	LF: +

C4-SUB loudspeaker

Nominal impedance	8 ohms
Power handling capacity (RMS / peak 10 ms).....	200 / 800 W
Connections	2 x Speakon-NL4
.....	(optional 2 x EP-5)
Pin assignments	2+ / 2-
.....	(EP-5: 3 / 4)
Weight	48 kg (106 lb)

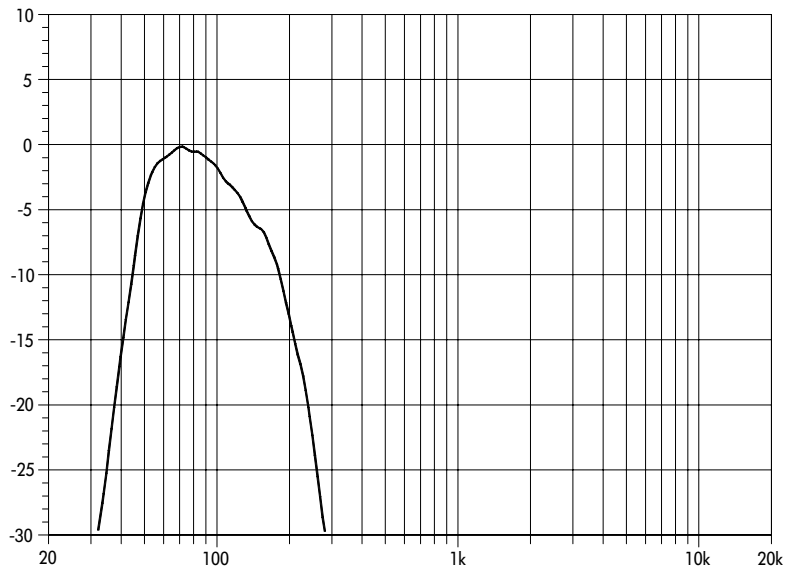

C4-SUB frequency response

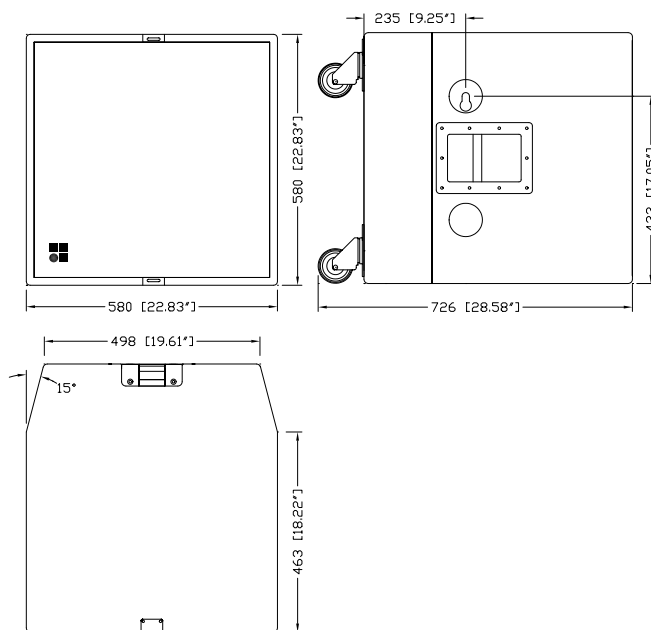

C4-SUB cabinet dimensions in mm [inch]

