

English
USER'S MANUAL



t.c. electronic
ULTIMATE SOUND MACHINES

DBMAX - V 2.90
DIGITAL BROADCAST MAXIMIZER

IMPORTANT SAFETY INSTRUCTIONS



The lightning flash with an arrowhead symbol within an equilateral triangle, is intended to alert the user to the presence of uninsulated "dangerous voltage" within the product's enclosure that may be of sufficient magnitude to constitute a risk of electric shock to persons.



The exclamation point within an equilateral triangle is intended to alert the user to the presence of important operating and maintenance (servicing) instructions in the literature accompanying the product.

- 1 Read these instructions.
 - 2 Keep these instructions.
 - 3 Heed all warnings.
 - 4 Follow all instructions.
 - 5 Do not use this apparatus near water.
 - 6 Clean only with dry cloth.
 - 7 Do not block any ventilation openings. Install in accordance with the manufacturer's instructions.
 - 8 Do not install near any heat sources such as radiators, heat registers, stoves, or other apparatus (including amplifiers) that produce heat.
 - 9 Do not defeat the safety purpose of the polarized or grounding-type plug. A polarized plug has two blades with one wider than the other. A grounding type plug has two blades and a third grounding prong. The wide blade or the third prong are provided for your safety. If the provided plug does not fit into your outlet, consult an electrician for replacement of the obsolete outlet.
 - 10 Protect the power cord from being walked on or pinched particularly at plugs, convenience receptacles, and the point where they exit from the apparatus.
 - 11 Only use attachments/accessories specified by the manufacturer.
 - 12 Unplug this apparatus during lightning storms or when unused for long periods of time.
-  Use only with the cart, stand, tripod, bracket, or table specified by the manufacturer, or sold with the apparatus. When a cart is used, use caution when moving the cart/apparatus combination to avoid injury from tip-over.
- 13 Refer all servicing to qualified service personnel. Servicing is required when the apparatus has been damaged in any way, such as power-supply cord or plug is damaged, liquid has been spilled or objects have fallen into the apparatus, the apparatus has been exposed to rain or moisture, does not operate normally, or has been dropped.

Warning!

- To reduce the risk of fire or electrical shock, do not expose this equipment to dripping or splashing and ensure that no objects filled with liquids, such as vases, are placed on the equipment.
- This apparatus must be earthed.
- Use a three wire grounding type line cord like the one supplied with the product.
- Be advised that different operating voltages require the use of different types of line cord and attachment plugs.
- Check the voltage in your area and use the correct type. See table below:

Voltage	Line plug according to standard
110-125V	UL817 and CSA C22.2 no 42.
220-230V	CEE 7 page VII, SR section 107-2-D1/IEC 83 page C4.
240V	BS 1363 of 1984. Specification for 13A fused plugs and switched and unswitched socket outlets.

- This equipment should be installed near the socket outlet and disconnection of the device should be easily accessible.
- To completely disconnect from AC mains, disconnect the power supply cord from the AC receptable.
- The mains plug of the power supply shall remain readily operable.
- Do not install in a confined space.
- Do not open the unit - risk of electric shock inside.

Caution:

You are cautioned that any change or modifications not expressly approved in this manual could void your authority to operate this equipment.

Service

- There are no user-serviceable parts inside.
- All service must be performed by qualified personnel.

IMPORTANT SAFETY INSTRUCTIONS

EMC / EMI.

This equipment has been tested and found to comply with the limits for a Class B Digital device, pursuant to part 15 of the FCC rules.

These limits are designed to provide reasonable protection against harmful interference in residential installations. This equipment generates, uses and can radiate radio frequency energy and, if not installed and used in accordance with the instructions, may cause harmful interference to radio communications. However, there is no guarantee that interference will not occur in a particular installation. If this equipment does cause harmful interference to radio or television reception, which can be determined by turning the equipment off and on. The user is encouraged to try to correct the interference by one or more of the following measures:

- Reorient or relocate the receiving antenna.
- Increase the separation between the equipment and receiver.
- Connect the equipment into an outlet on a circuit different from that to which the receiver is connected.
- Consult the dealer or an experienced radio/TV technician for help.

For the customers in Canada:

This Class B digital apparatus complies with Canadian ICES-003.

Cet appareil numérique de la classe B est conforme à la norme NMB-003 du Canada.

Certificate Of Conformity

TC Electronic A/S, Sindalsvej 34, 8240 Risskov, Denmark, hereby declares on own responsibility that following products:

DBMAX - Digital Broadcast Maximizer

- that is covered by this certificate and marked with CE-label conforms with following standards:

EN 60065 (IEC 60065)	Safety requirements for mains operated electronic and related apparatus for household and similar general use
EN 55103-1	Product family standard for audio, video, audio-visual and entertainment lighting control apparatus for professional use. Part 1: Emission.
EN 55103-2	Product family standard for audio, video, audio-visual and entertainment lighting control apparatus for professional use. Part 2: Immunity.

With reference to regulations in following directives:

73/23/EEC, 89/336/EEC

Issued in Risskov, February 1th 1998
Anders Fauerskov
Managing Director

TABLE OF CONTENTS

INTRODUCTION

<i>Table of Contents</i>	3
<i>Quick Start Guide</i>	4
<i>Introduction</i>	5
<i>Front Panel</i>	6
<i>Rear Panel</i>	8
<i>Signal flow diagram</i>	9
<i>DBMAX setup</i>	10

BASIC OPERATION

<i>Reference Levels</i>	12
<i>Reference Levels Illustration</i>	14
<i>Recall</i>	15
<i>Store - Delete and Preset Names</i>	16

MAIN PAGE

Input	18
Inserts	
<i>AGC</i>	22
<i>Parametric EQ</i>	22
<i>90 deg. mono</i>	22
<i>Dynamic Equalizer</i>	24
<i>Stereo Enhance</i>	24
<i>Normalizer</i>	26
<i>MS Decoding</i>	26
<i>MS Encoding</i>	26
Expander	28
Compressor	30
Limiter	34
Inserts - Post Dynamic	
<i>Transmission Limiter</i>	36
<i>Production Limiter</i>	36
Output	
<i>Dither</i>	38
<i>Fade</i>	38

Tools

<i>Flow</i>	40
<i>Surround Meter</i>	40
<i>Peak-Hold Meter</i>	41
<i>Phase Meter</i>	41
<i>Digital I/O</i>	42
<i>Calibration Tone</i>	42
<i>Utility</i>	44
<i>Reset page</i>	46
<i>The WIZARD</i>	47

APPENDIX

<i>Trouble Shooting</i>	48
<i>Self test</i>	49
<i>Technical specifications</i>	50
<i>Tutorial</i>	51
<i>Glossary</i>	53
<i>Soldering instructions</i>	54
<i>Preset list</i>	56
<i>FAQ</i>	58
<i>Optional Master Fader</i>	59

QUICK START

We recommend you read the entire manual before using the DBMAX, but if you're anxious to get started we suggest you take the following steps in the described sequence.

- 1 Connect analog and/or digital I/O and power to the unit. The DBMAX will adapt to the power being used in your area without you having to select a voltage.
- 2 Turn on the POWER switch at the rear, and press the POWER key on the front.
- 3 On LCD IN page 1, select analog, S/PDIF or AES/EBU Input.
- 4 Press the REF. LEVELS key and set your I/O level conditions:
 - 4.1 If you use analog Inputs or Outputs, adjust the analog level required for digital full scale by selecting a proper value for the In Level parameter. When a correct In Level is selected, the red LEDs on the INPUT meter should never light up, and indication should be in the -18 to -6dB range.
 - 4.2 Your normal operating level, typically the level at which you would want a calibration tone, may be set as Reference Level. In a broadcast environment, the Reference Level would normally be set 18-20dB below your In Level. If you only want to relate to digital full scale, turn the Reference Level all the way up.
 - 4.3 The Abs.Peak Output setting determines the maximum instant peak Output level from the DBMAX. If you work against digital peak meters or in transmission, the setting should be spot on. If you work in an environment depending on analog PPM meters, this setting should be 3-4 dB above the maximum level allowed with the meter. If you work against VU meters, the setting should be 12-20dB above the 0VU level.
- 5 Press the WIZARD key and select the type of limiting/compression you want by using the PARAMETER keys and the ADJUST wheel.
- 6 Press the OK key. Play some program material and leave the Wizard working while you are playing a soft part and a loud part of the type of signal the DBMAX will be processing. 10 seconds of each will do.
- 7 Press the OK key again, and the DBMAX has loaded a best fit parameter setting for your application and source material.
- 8 If required, go to the COM block in the MAIN PAGE, and adjust the More/Less setting to suit your taste. Turning the control to Less makes the unit behave as a Limiter. Turning the control to More makes the unit behave like a maximizer.
- 9 No more overs. Enjoy!

INTRODUCTION

Congratulations on the purchase of your new DBMAX.

We hope that you will have as much pleasure using it as we had making it.

The DBMAX V2.02 is the result of hard work by TC Electronic's skilled developers, based upon the experience of some of the best qualified transmission engineers in the business. The DBMAX V2.02 is TC Electronic's second generation of broadcast compressors. Stuffed with all the necessary tools, a strong collection of presets as well as a selection of predefined Level setups, the DBMAX could be a difficult unit to operate. But nicely wrapped in TC's award winning highly intuitive design, you will soon be ready to operate it.

We invite you to have your Input/Output and reference level specifications included in later software releases. Other DBMAX owners will then very easily comply with your specifications when delivering program material to your station or production house.

For suggestions please contact TC Electronic at: info@tcelectronic.com

Please keep informed on the latest updates either via our internet site at www.tcelectronic.com or contact TC Electronic directly.

General features in the DBMAX version 2.02

Versatile multi-band Compressor/Limiter/Expander with switchable architecture between 1 and 5 bands

Minimum distortion algorithms utilizing 24 and 48 bit processing

New Less/More for control of multi-band compression

Processing at any Sample Rate between 32 and 48kHz

Relay bypass of analog I/O on power-down

Unlock detection of digital Input

Audio bandwidth to 24kHz, or variable lo-pass filtered for FM transmission

24 bit resolution AD and DA converters and built in optional Sample Rate converter

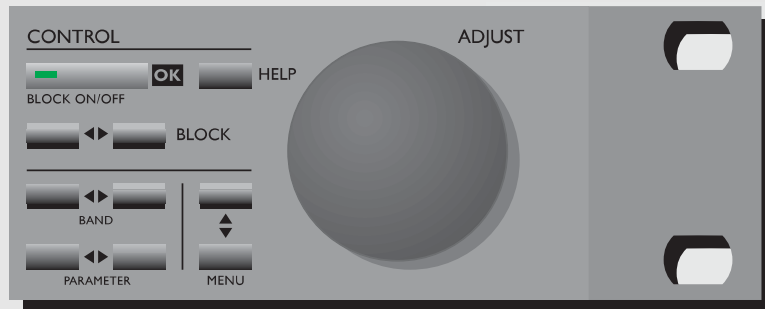

Useful features for Production

- Level settings for a number of Radio and TV stations
- 5-band parametric EQ insert
- Stereo Enhancer insert
- 90° mono insert
- MS Decoding insert
- MS Encoding insert
- Dynamic EQ and De-esser insert
- Production Final Limiter providing PPM attack response
- Production Final Limiter providing adjustable Soft-Clip
- Dedicated presets for Film and Post Pro Mastering
- Dedicated presets for Production Recording
- Dedicated presets for CD Mastering

Useful features for Continuity and Transmission

- Final TX Limiter providing Emphasis compensated HF limiting
- Final TX Limiter providing adjustable Soft-Clip
- RS485 remote control
- 90° mono insert
- AGC insert
- Stereo Enhancer insert
- 5-band parametric EQ insert
- Dynamic EQ and De-esser insert
- Dedicated presets for Continuity Limiting
- Dedicated presets for Continuity AGC (1-5 bands)
- Dedicated presets for gentle Transmission processing
- Dedicated presets for aggressive Transmission processing

FRONT PANEL

ELECTRONIC POWER SWITCH

»Easy touch«
Keep pressed for more than 2 seconds to turn device off.

DEFINED OVERLOAD

User defined overload LED.

OUTPUT PPM

High resolution meters.

CLIP LED

Indicates that Output is clipped.

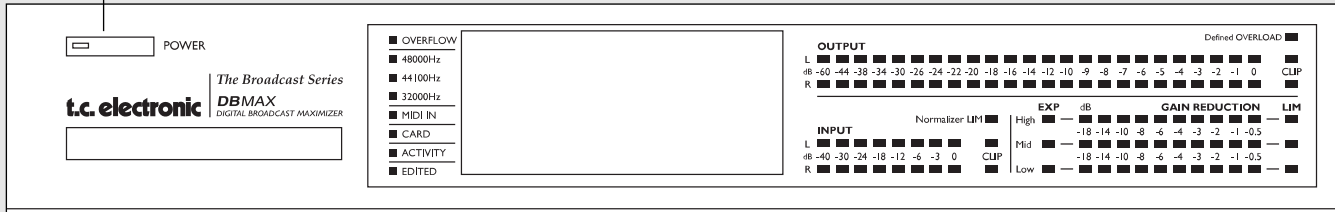

PC CARD SLOT

Presets may be copied to/from a standard PCMCIA/PC-CARD memory card.

INDICATORS

OVERLOAD LED

Lights up if internal overload occurs.

INPUT SAMPLE RATE INDICATOR

48000 Hz
44100 Hz
32000 Hz

MIDI IN LED

MIDI or RS485 receive indicator.

CARD LED

Indicates presence of a valid memory card.

ACTIVITY LED

Indicates when a calculation is performed.

EDITED LED

Indicates that the preset has been edited.

INPUT PPM

EXPANDER ACTIVE INDICATORS

GAIN REDUCTION METERS

LIMIT LEDS

High - Indicating the max gain reduction in the two high freq.bands.

Mid - Indicating the max gain reduction in the mid freq. bands.

Low - Indicating the max gain reduction in the two lower bands.

FRONT PANEL

ADJUST wheel
Sets parameter values and
preset numbers.

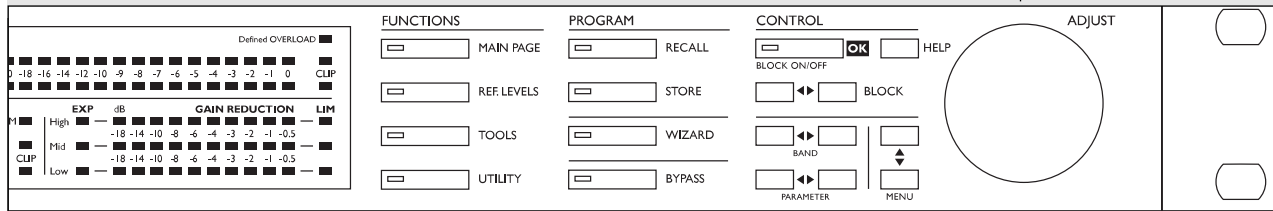

FUNCTIONS SECTION

MAIN PAGE

This key allows you to edit the entire signal flow, from Input to Output.

REF. LEVELS

All I/O levels are set here.

TOOLS

This key gives you access to a lot of useful tools for optimizing your material.

UTILITY

Security, Timing calculations, Memory management and others.

PROGRAM SECTION

RECALL

Recall presets.

STORE

Store and name presets.

WIZARD

The Wizard guides you thru some of the hard work of finding the correct settings of essential parameters.

BYPASS

Bypass the signal processing.

CONTROL SECTION

OK

Confirm operations and switch individual blocks on/off.

HELP & LOCK

Get help on selected display by pressing the HELP key. Press and hold to activate/deactivate Front Panel Lock function.

BLOCK <>

Select which block to edit on the Main page.

MENU up/down

Vertically oriented menu selector.

PARAMETER <>

Moves horizontally for selection of parameter to be modified.

BAND <>

Select between the five bands on the Com/Lim/Exp pages. On the EQ page, the BAND keys select which of the five EQ filters are displayed and ready for modification.

REAR PANEL

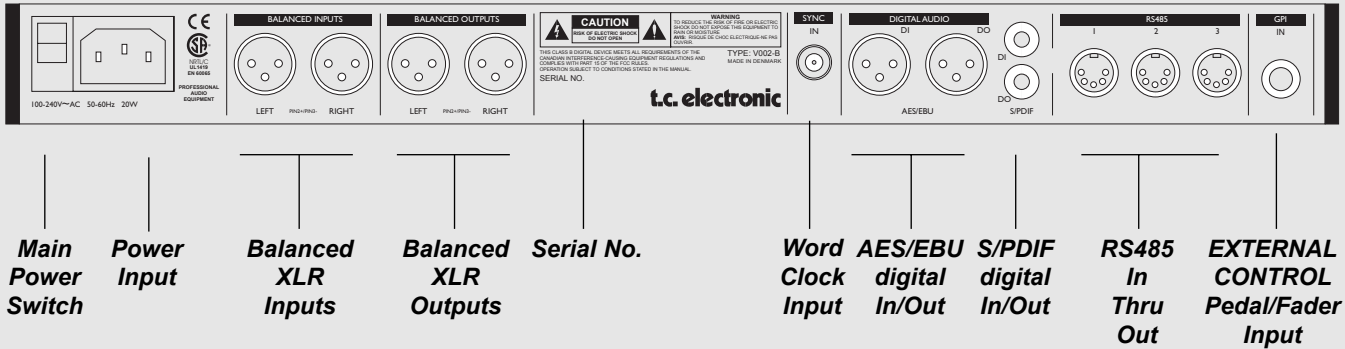

NOTES:

To comply with international regulations, we have also added a rear panel **POWER** switch. You don't need to use the **POWER** switch on the rear panel. Use the front panel **POWER** switch instead.

Pin 2 is »hot« on all XLR's (IEC and AES standards). For soldering instructions please refer to page 55.

If you are connecting the **DBMAX** to unbalanced equipment, you must tie pins 1 and 3 together in the cable ends away from the **DBMAX**.

NOTE!

Pins 1 and 3 on the **DIN** connectors serve as **RS485** connection. Therefore, if you are connecting the unit to other equipment that use these pins, please make sure to use 3-wire standard **MIDI** type cable (not a five wire **MIDI-PLUS** type).

If you want to use the **Pedal Input**, make sure it is a momentary type.

SIGNAL FLOW

DBMAX

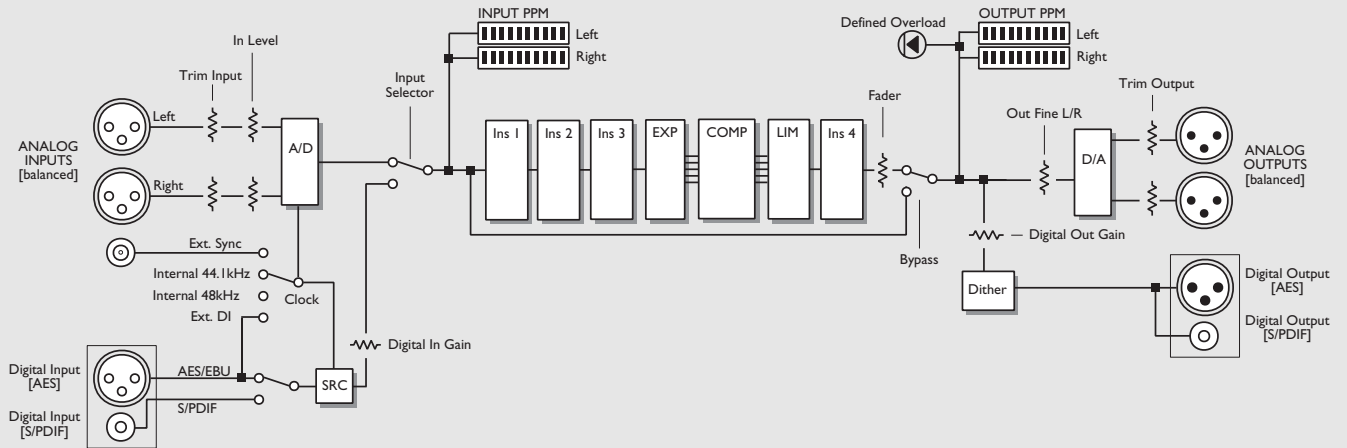

DBMAX SETUP

The DBMAX is carefully designed to optimize or limit the overall level and enhance the energy in your material. The use of the five band Compressor, Limiter and Expander makes the dynamics section of the DBMAX very flexible, while maintaining the fidelity of the original material. The dynamics section, in combination with a Normalizer, AGC, EQ, De-esser etc. makes the DBMAX a very powerful tool for optimizing the current signal. Because the DBMAX can be used in different applications, we propose a few different setups.

Radio Production & Transmission applications

DAB production or FM Production suite

The two applications for the DBMAX in this configuration are:

1. The DBMAX can be inserted pre master, to optimize the production.
2. The DBMAX can be inserted post master to emulate the signal processing in transmission.

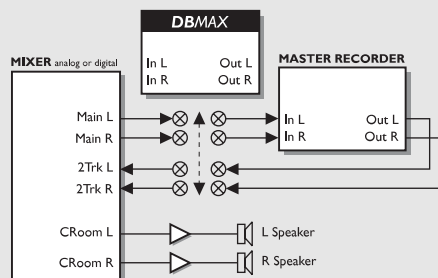

Transmission

The two applications for the DBMAX in a transmission situation:

1. Digital Broadcast: DBMAX optimizing, limiting and equalizing the signal for digital Audio Broadcast.
2. FM broadcast: DBMAX optimizing, limiting and equalizing the signal in proportion to the current pre-emphasis.

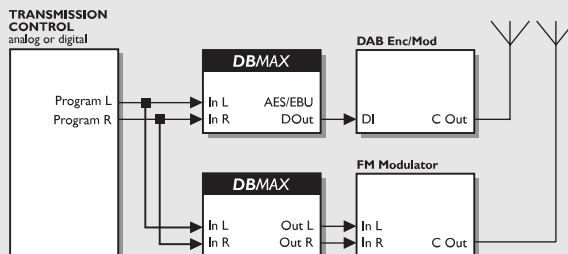

TV Production & Transmission applications

Surround Production Suite

The two applications for the DBMAX in this configuration are:

1. The DBMAX can be inserted pre master, to optimize the production.
Note: Adjusting the L/R balance can cause serious changes to the surround encoded signal.
2. The DBMAX can be inserted post master to emulate the signal processing in transmission.

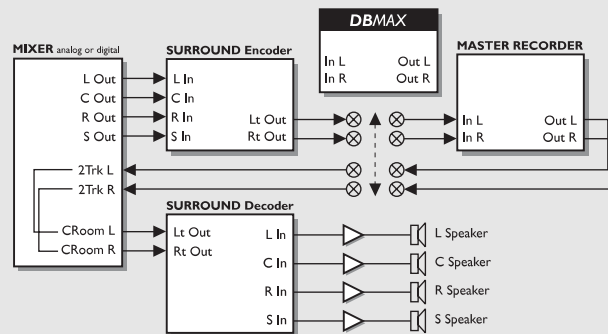

TV continuity/Transmission

The two applications for the DBMAX in a transmission situation are:

1. Digital Sound: DBMAX optimizing, limiting and equalizing the signal for NICAM (or other systems) using the wordclock as ext. sync.
2. FM Sound: DBMAX optimizing, limiting and equalizing the signal in proportion to the current pre-emphasis, generating mono (0° or 90°).

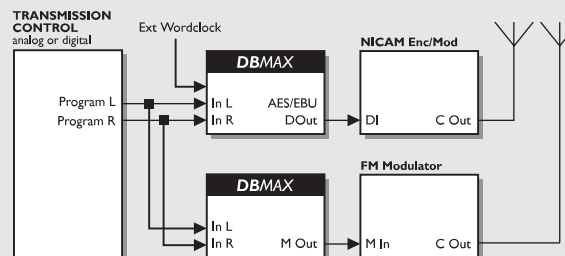

REFERENCE LEVELS

I/O Levels

SETUP:

▶ Load Setup : **PRESS OK**
Save Setup : **PRESS OK**

OPERATING LEVELS:

Ref. Level : 0dBu
(dBFS) : -18dB
Abs. Peak max : +9dBu
(dBFS) : -9dB

ANALOG LEVELS:

InLevel 0dBFS: +18dBu
Trim Input : 0dB
Trim Output : 0dB

DIGITAL LEVELS:

Input Gain : 0dB
Output Gain : 0dB

DEFINED OVERLOAD LED:

Overload : +6dBu
(dBFS) : -12dB
@Integration : 10ms

FRONT PANEL OUTPUT METERS:

Ref : 0dBFS
Peak Hold : 1s
ClipLed def.: 4sampl.

BYPASS DEFINITION:

Bypass using : 1:1

The Reference level settings are the heart of the DBMAX. If these parameters are not set properly, the DBMAX may not perform correctly. So please take the time to go through these level settings and make sure they are set correctly.

The DBMAX is prepared to match several different predefined Reference Level setups. These setups could be considered as “level presets”. In addition to these presets you can store four setups of your own.

Basic operation

- Use the MENU keys to select parameter.
- Use the ADJUST wheel to change value.

Setup

Load Setup

- Select “Load Setup” by pressing the grey OK key, and scroll through the list using the MENU keys.
- Select an environment/application resembling your own, and press OK.

Save Setup

It is possible to store four different custom user setups.

- Place the cursor next to “Save Setup” using the MENU keys.
- Press OK and use the MENU keys to select the location where you want to store the setup.
- Confirm with OK to store the preset with the same name or change the name before storing.

To change the name before storing:

- Use the PARAMETER keys to select letter-position and the ADJUST wheel to select letter.
- When you have the desired name in the display, press OK to store the setup with the new name.

All parameters in Ref. Levels will be saved.

Operating Levels

General advice

If you use analog Inputs or Outputs, first adjust the analog levels In Level setting to define the analog level for digital full scale (FS). The Ref. Levels setting should be adjusted for nominal signal level, which is both expressed in dBFS (digital) and dBu (analog). The Abs. Peak max setting should be adjusted for maximum instant peak permitted Output level.

REFERENCE LEVELS

Ref. Level

With Reference level you can set the reference point of the Compressor to eg. +4dBu. All Thresholds, except the Limiter Thresholds, are relative to this parameter. The Reference level parameter is adjustable in dBu and dBFS.

Abs. Peak max

Sets the hardclip point of the DBMAX. Absolute peak means that notching occurs above this level digitally. Absolute Peak Max. is adjustable in dBu and dBFS.

Analog Levels

In Level 0dBFS

Sets the dBu level you want to equal to 0dBFS (Full Scale), i.e. setting this parameter to +18dBu, means that when you are sending +18 dBu out of your desk, the DBMAX will be showing 0dBFS.

It is very important that you set this parameter correctly as all other dBu levels are relative to it.

Trim Input

This parameter trims the level of the analog Input for digital full scale (FS). Correct trimming optimizes the 24 bit AD converters performance in conjunction with the trimming of the Output parameters.

Trim Output

Trims the analog Output level. This parameter may be trimmed in 1dB steps.

Digital Levels

Input Gain

Sets the digital Input level. Use this if you need to trim a source to a new level. A typical situation could be trimming down the digital Output of a CD-player. All trims may be stored using the Save setup command.

Output Gain

Sets the digital Output level.

Define Overload LED

Overload

This parameter allows you to custom-define the DEFINE LED. The Overload level can be set anywhere between -30 dBFS and 0 dBFS. The Overload parameter is adjustable in dBu and dBFS.

Integration

To simulate different types of meters, the defined overload can work in proportion to an integration time. Digital meters have an integration time of 0ms where analog meters typically have an integration time of 10ms.

The Integration time can be set to 0 ms, 1 ms, and 10 ms.

Front Panel Output Meters

Ref

You can set the Output meters to refer to digital Full Scale (dBFS), which is the default, or Clip which means that the meters are referring to “Absolute Peak” as 0 dB. When set to Clip you will take full advantage from the Output meter.

Peak Hold

Set the desired Peak-Hold time with this parameter. Choose between Off, 1, 2, 5, or 10 seconds.

Clip LED def.

You are able to define when you want the CLIP LEDs to be activated. Choose the number of consecutive samples to be at 0dBFS before the CLIP LEDs are activated.

Bypass Definition

Att.

When bypassing the DBMAX in this mode the signal will not exceed the Abs. peak max level set in the Ref. Levels - I/O Levels menu.

1:1

Use this setting if you want to bypass the signal but apply Dither and delay.

Thru

Use the Thru setting to bypass the entire signal bit by bit.

REFERENCE LEVELS

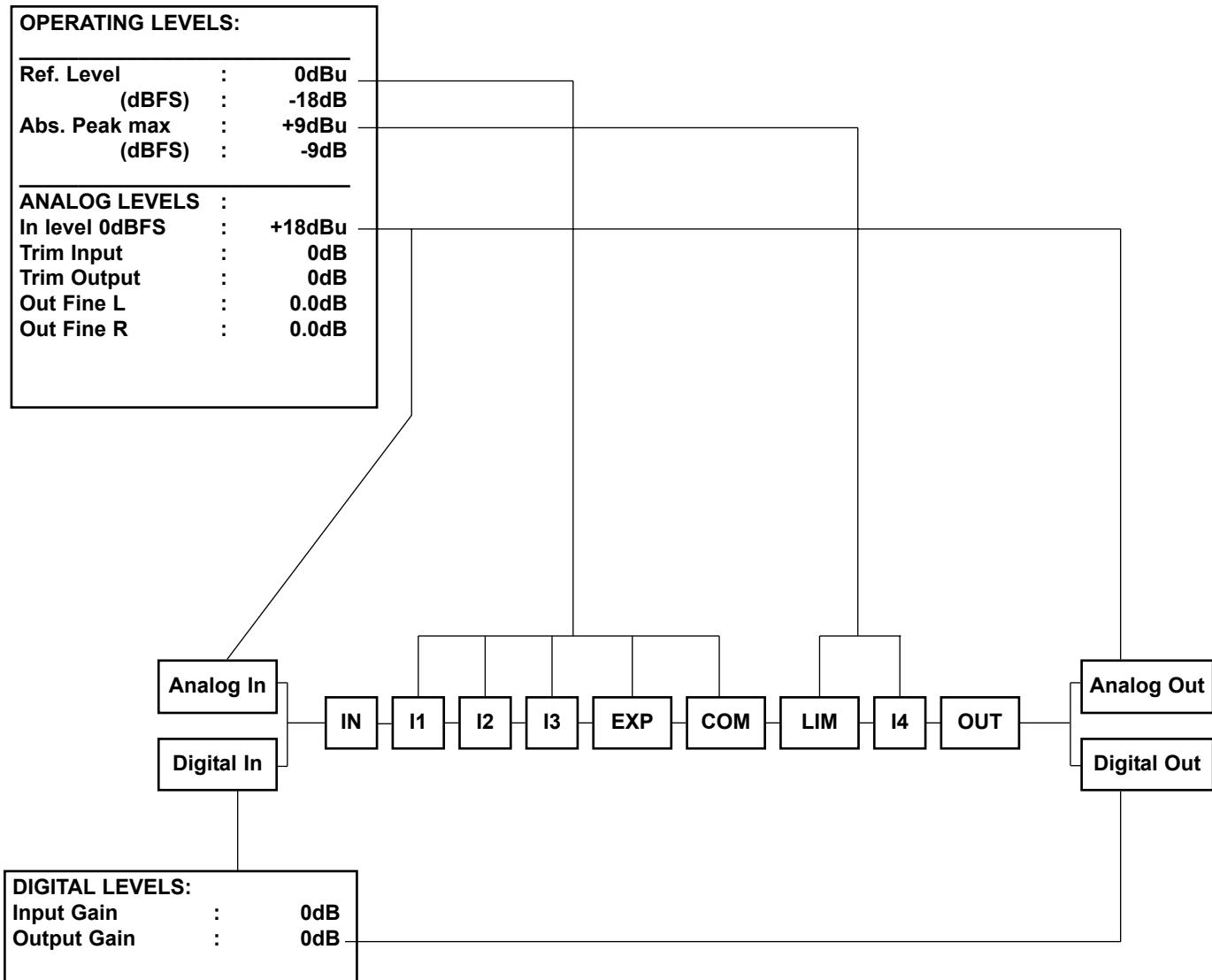

RECALL

Select which blocks to load from the new preset

Select Preset Category

Preset name

Read only/On air indication

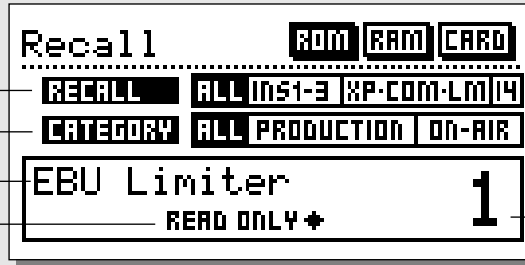

Bank indication

Preset number

Press the **RECALL** key to enter the Recall page.

To recall/activate a preset:

- Use the ADJUST wheel to scroll through the presets. Until you confirm your choice you are previewing the presets. At this stage the OK LED will be blinking.
- When you find the desired preset press OK to recall/confirm.

Recall conditions

It is possible to set up a couple of conditions for the preset that you are about to recall. Use the MENU keys to step through the filters.

Recall

This function enables you to make a partial recall where you recall segments from a new preset and implement them in the currently recalled preset.

- Use the MENU keys to place the cursor at the Recall line.
- Use the ADJUST wheel to select which parts from the new preset you wish to implement in the current recalled preset.

Your Recall options are:

- All - To recall an entire new preset.
- INS 1-3 - To recall all insert settings in Insert 1-3.
- XP-COM-LIM - To recall all settings in the Expander, Compressor and Limiter
- 14 - To recall all insert settings in the post dynamics Insert 4

Category

This filter enables you to select presets by category. Select "All" or a specific category and you will now only be previewing presets from the current category.

Factory/User Presets

Factory Presets

65 ROM PRESETS

Your own Presets

128 RAM PRESETS

Your own Card Presets

128 CARD PRESETS

The DBMAX contains two different preset banks and a card bank if you use a PCMCIA card.

The RAM bank can hold up to 128 presets.

The RAM preset bank is located after the ROM bank.

The card bank is located after the RAM bank.

Scroll through the ROM presets to enter the RAM bank. Scroll through the RAM bank to access the CARD bank.

 **For fast RAM/ROM access use the BLOCK keys to switch between the banks.**

Note: When previewing the RAM bank you will not see the empty RAM spaces.

STORE - DELETE & PRESET NAMES

Store

Storing a preset with the same name

- Press the STORE key.
- Place the cursor next to the "Name" line (see illustration).
- Select a location for your new preset using the ADJUST wheel (You can store your preset in the RAM bank or the Card bank).
- Press OK and the preset is stored with the same name at the selected location.

Storing a preset with a new name

- Press STORE and place the cursor at the "Name Edit" line using the MENU keys.
- Type the new preset name. Use the PARAMETER keys to select letter position and the ADJUST wheel to select letter.
- Press OK and the preset is stored with the new name at the selected location.

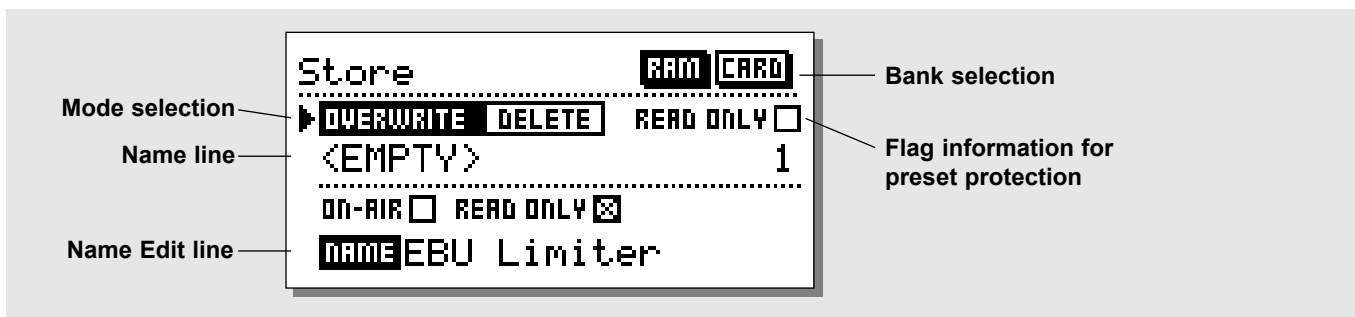

Flags

When storing a preset, you may give it two flags:

- ON-AIR :Use the ON-AIR flag for easy identification and sorting of presets.
- READ ONLY :Important presets may be marked with the READ ONLY for protection. A preset with this flag cannot be overwritten by another preset. A pop-up display will tell you that the preset is write protected.

Note: The READ ONLY flags may be disregarded if you wish to replace the entire RAM bank from the Utility page.

Deleting a Preset

To delete a preset in the internal RAM bank or PCMCIA card:

- Press STORE.
- Use the MENU keys to move to the top line, and use the ADJUST wheel to select DELETE.
- Use the MENU keys to move down one line, and choose the preset you wish to delete by using the ADJUST wheel.
- Press OK.

Overwriting or Deleting Protected Presets

- Press STORE.
- In the top line use the PARAMETER keys and the ADJUST wheel to remove the READ ONLY flag.
- Make selections regarding Overwrite, Delete, Location, new Flags and Title as described above.
- Press OK to store or delete.

Using a Memory Card

If you wish to use a memory card, simply insert the card in the DBMAX. The DBMAX will now autodetect your card and the Store and Recall facilities will be attached to the memory card. If the format of the memory card is not correct, the DBMAX will detect this immediately.

Card types

Type 1 PCMCIA cards with a minimum of 64KB SRAM and a maximum of 2 MB.

What is stored where ?

Global Parameters

Global parameters describe your general working environment: Inputs used, System delay, Settings for Transmission or Production etc. Global parameters are not affected by setup or preset recalls. The parameters include:

- Input and Output Blocks on the Main Page:
 - Delay, Formats, HP and LP Filters, Rate Conversion, Dither and Output Fader.
- Parameters in the Utility Page:
 - Display Angle, RS485, Security, General Purpose Input.
- Parameters in the Tools digital Out Page.
- User Data, Name and Phone and Keyboard lock.

Setup Parameters

Setup parameters describe the interface and Reference Levels in your environment. Setup parameters are not affected by preset recalls.

If you need to deliver the same program to different Output level conditions, you may keep your preset and load a different setup. Preset parameters may change with every preset and when the Wizard is invoked.

MAIN PAGE *Input*

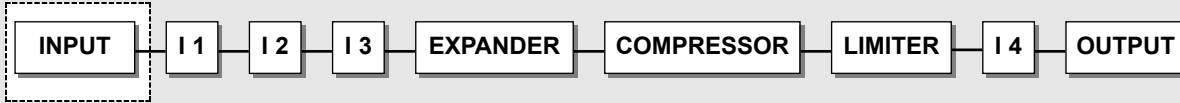

Input page 1

Black box indicates selected block

Page select

Input type selector

Master Input Delay in frames pr. second

Delay on/off switch

Sample Rate converter on/off

Clock select

Master Input delay in milliseconds

Input page 2

Lo Cut adjust

Hi Cut adjust

Reference level selection
Choose whether the setup should follow preset changes or not.

Process both channels (normal) or only Left or Right

Basic operation

- Select the In section on the Main page by pressing the BLOCK keys.
- Press the PARAMETER keys to move the cursor.
- Use the ADJUST wheel to change values.
- Use the MENU keys to switch between In page 1 and In page 2.

The In block settings are Global parameters.
Global Parameters are not affected by preset or setup changes.

Analog I/O levels are scaled in the analog domain and controlled from the Ref. Levels page using the analog levels In Level parameter. This is where you establish a basic relationship on both Outputs and Inputs between analog level and digital full scale. Also Inputs and Outputs may be offset individually on this page. The settings are part of the Setup parameters.

Input page 1

Input

Select Input type.

Options are Analog, AES/EBU or S/PDIF

When a digital Input is used, the transmitting device and the DBMAX need to run at the same Clock Rate, or Sample Rate Conversion (SRC) has to be used.

If the SRC is off, you have to put either the DBMAX in External Clock mode, or the transmitting device has to get a clock from the same source as the DBMAX.

To test the digital connection, try listening for a minute or so to a sine tone at say -18dBFS generated by the transmitting device. If you hear no distortion or glitches, you've probably got it right.

Sample Rate Conversion

Sample Rate Conversion may be applied to the AES/EBU or S/PDIF Input. The Input Sample Rate may be asynchronous. The Output of the Sample Rate converter is locked to the system Clock source.

Internal references at 44.1 or 48kHz or an external Word Clock signal may be used to drive the Sample Rate Converter and thus the rest of the system. Even though the Sample Rate Converter of the DBMAX has a wide dynamic range and low distortion (-106dBFS), synchronous data transfers are complete and should be used if possible.

It is not possible to loop through Channel Status or User Bits on the AES/EBU interface, when the SRC is inactive.

Clock - Output Sample Rate

Select Master Clock:

44.1kHz/48kHz/DI/Sync

(44.1 and 48kHz are internally generated).

The Output Sample Rate (= system rate) of the DBMAX is always set in the Clock box of the In page no 1. Normally 48kHz is used for production in PAL and SECAM countries. 32 or 48kHz are normally used for transmission. 44.1kHz is used for regular audio CDs.

Sample Rate LED's

When a digital Input is used, and the signal is recognized, one of the three yellow RATE LEDs light up. If no signal is present, and you've selected a digital Input or Insert, all three LED's will blink.

Note: Blinking LEDs indicate a lock error condition.

The Outputs of the DBMAX will be muted and the digital audio Inputs and the BNC wordclock Input may be used as a synchronization source for the analog Inputs (AES II).

When using Ext. wordclock, from the BNC connector, select Sync.

Note: When changing the Input to digital, the Sample Rate parameter automatically defaults to DI.

Delay - Master Input Delay

This Delay parameter enables you to delay the entire signal through the DBMAX. The delay can be set in various Frame Rates or in milliseconds.

The Delay through the unit is made up by (values given @ 48kHz sampling):

- AD Converter Delay 0.8ms
- DA Converter Delay 0.57ms
- Processing Delay 0.54ms
- Look Ahead Delay typical 2-3ms
- User additional Delay 0-400ms

On the Input Page, the delay value is shown in total, but excluding the delay from the AD and DA converters.

To obtain the best sound quality through the multi-band compression stage a delay value between 1 and 10ms is preferable. A typical value for transmission would be 2-3ms. A typical value for production would be 2-10ms. If you add additional delay (e.g. link compensation), maximum Look-ahead delay is automatically given.

MAIN PAGE *Input*

Look-ahead delay is automatically compensated by the Compressor Attack settings in order prevent “holes” in the sound being generated.

Maximum delay: 400ms/10 frames

Note: The Delay setting is NOT recalled with a preset, but the Attack compensation is.

Input page 2

Low Cut

The Lo-Cut filter is global, and is used to filter out any sub-bass frequency or DC contents in the signal.

For FM processing Lo-Cut should be set between 20 and 40Hz.

Hi-Cut

The Hi-Cut filter is global and is used to remove high-end frequencies. This function is relevant if the processed signal should be used in e.g. FM, AM or WWW-Audio. Since these formats do not transmit frequencies above approx. 16kHz, high frequency peaks would unnecessarily invoke the Compressor/Limiter unless the Hi-Cut function is not used.

Hi-Cut filters are high order and provides additional Pilot tone notching at 19kHz.



If very “hot” digital Inputs are used for FM transmission, we recommend trimming the digital Input level down by 1dB on the Ref. Levels page in order to prevent overloading the Input filters. Please see page 12 for explanations on Ref. Levels.

Reference Level

It is possible to keep the Reference Levels settings as default settings or let these settings follow the presets:
“NO CHG” - Use this setting to keep the selected Ref. Level setting independent of preset changes.

Ref. Level

setting 1-19 - Use this setting to store a Ref. Level setting with the preset. By letting a group of presets refer to a single Reference Level setup, you are able to adjust/control the Reference Levels setup attached to an entire category of different presets.

Process

Normal : Both channels will be processed
Left only : Only the left channel will be processed
Right only : Only the right channel will be processed.

MAIN PAGE *Inserts 1-3*

On the following pages the different Insert options are explained. Please use this illustration for overview of the level handling in accordance to various parameters in the DBMAX .

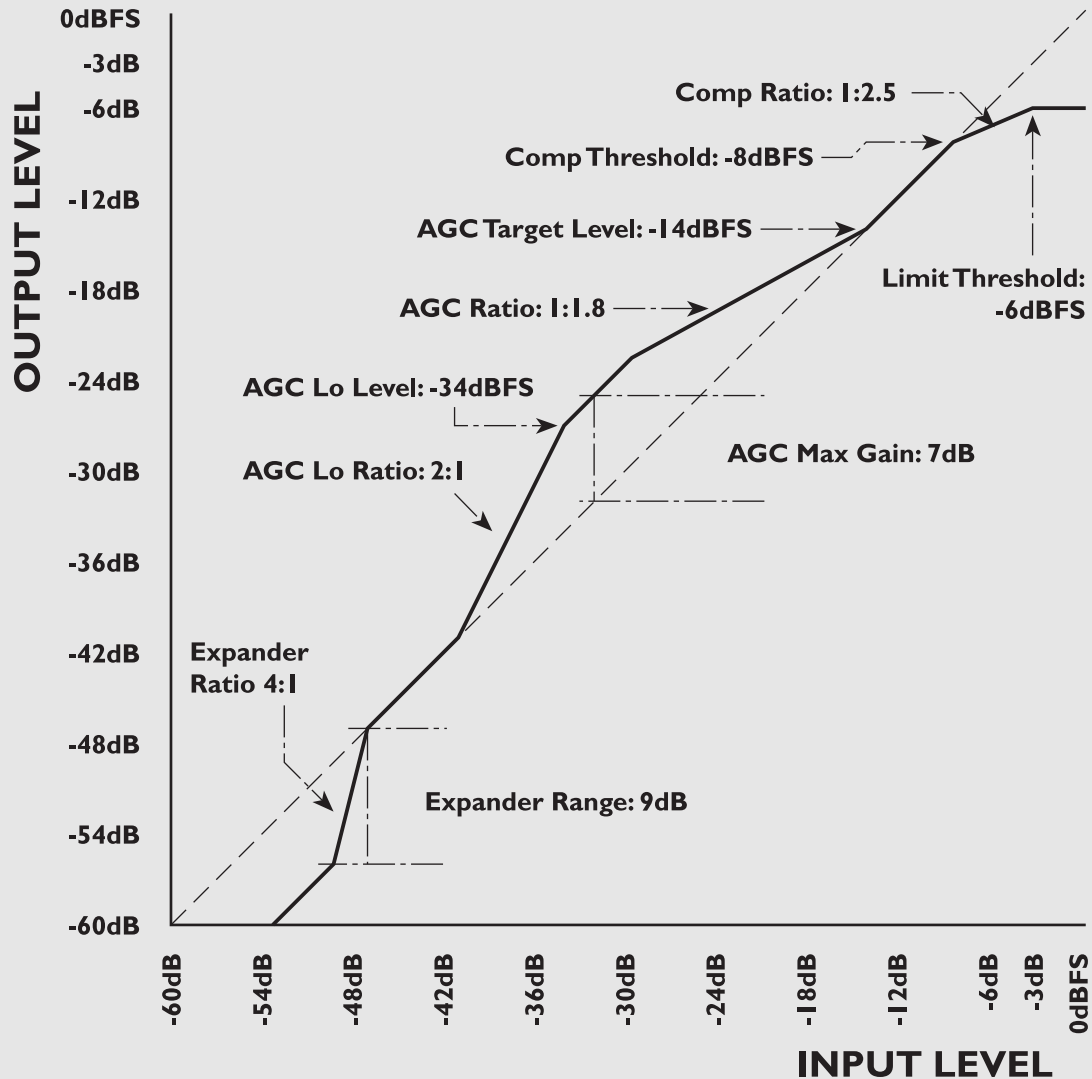

MAIN PAGE *Inserts 1-3*

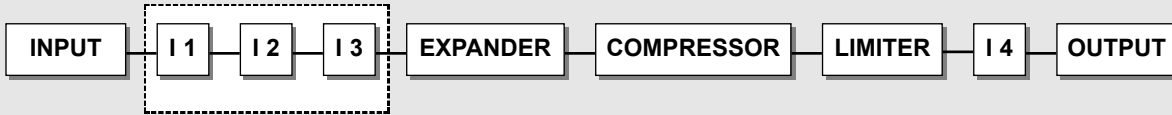

AGC
Automatic Gain Control.

Min/Max Gain
Maximum/minimum gain limit you allow the AGC to perform on your signal.

Low Level Target
Low level limit for the AGC.

Target
Target level for the AGC.

Ratio

Hold

Release:
AGC Release rate in dB/sec.

Parametric Equalizer

Gain
Manual Make-up gain or EQ match.

Frame indicates selected band

Frequency

Band Level

Curve Type

90° MONO

Inserts

Select Insert 1, 2 or 3 by pressing the BLOCK keys

Basic operation

- Use the MENU keys to highlight the field just below the Insert-line.
- Use the ADJUST wheel to select the insert type.
- Press the PARAMETER keys to select parameter.
- Turn the ADJUST wheel to change values.

The DBMAX has various Insert possibilities:
AGC, Parametric Equalizer, 90° deg. Mono, Dynamic Equalizer, Stereo Enhance, Normalizer, MS Encoding, MS Decoding.

Note: You can not use the same Insert type in two different Insert blocks at the same time.

AGC - Automatic Gain Control

The AGC is really a very slow compressor, used to guarantee that the signal is kept within a certain dynamic range and it is an excellent tool to compensate for the different output levels on your program material.

Unlike a regular compressor, the AGC will smoothly adjust the Output level over a relatively long period of time (approx 1 sec.), giving you a constant average level. An Attack time this long could introduce problems with transients. This problem is dealt with in a built-in selfprotective function which enables transients to invoke a fast response time (only 8 samples). The Attack time can therefore be perceived as adaptive and flexible.

Max and Min Gain

This is the Max/Min changes in gain you allow the AGC to perform on your signal, and these parameters are to be considered as the master parameters of the AGC.

E.g. when Max. gain is set to 6dB, only 6dB gain can be performed regardless of a higher Target value.

If Min. level is set to -6dB this is the Max. attenuation the AGC can perform.

If both Min. and Max. are set to 0, no gain correction will be applied by the AGC.

Low level

If the signal is below the Low Level value, the AGC will add no gain. This is a function to prevent the AGC from boosting background noise.

Target

This is the Target value in dB related to the Ref. Levels setting.
Example:

- The Ref. level is set to e.g. -12dBFS,
 - The Target level is set to 2
 - The Max. gain is set to 2dB or higher
- The AGC will gain the signal to -10dBFS.

Ratio

Sets the Ratio for the AGC function.

Hold

Sets the Hold time for the AGC.

Within the set Hold time the AGC can keep the signal at constant level, even if the level of the Input signal briefly drops radically.

Release

Release Rate in dB/sec. Up to 9.9dB/s is allowed.

Parametric EQ

Basic operation

- Press PARAMETER keys to select:
Frequency/Gain/Bandwidth/Slope.
- Turn ADJUST wheel to change values.
- Press BAND keys to jump between the five bands.

EQ Ranges

Filter Types	Frequency	Bandwidth/Slope
Low Shelving filter	19.95Hz to 5.01kHz	3, 6, 9, 12dB/Oct
Bell-shaped filter 1	19.95Hz to 20kHz	0.1Oct to 4.0Oct
Bell-shaped filter 2	19.95Hz to 20kHz	0.1Oct to 4.0Oct
Bell-shaped filter 3	19.95Hz to 20kHz	0.1Oct to 4.0Oct
High Shelving filter	501.2Hz to 20kHz	3, 6, 9, 12 dB/Oct

Gain-range for all filters is +/- 12dB

Gain-range for the Gain is +/- 12dB

90° Mono

This function makes it possible for surround signals to be compatible with mono signals. The slight phase change enables you to reproduce signals that otherwise would have disappeared in a mono situation.

May be used for monitoring or for actual live processing.

The Output of the 90° mono circuit is mono, L=R.

Note! The 90° mono block has no adjustable parameters.

MAIN PAGE *Inserts 1-3*

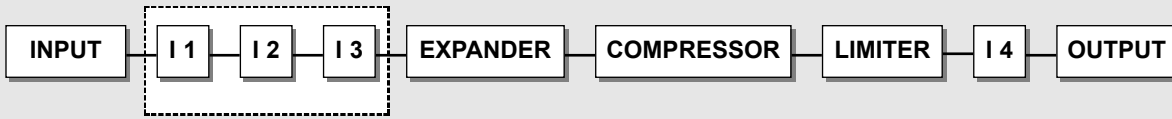

Black box indicates selected block

Dynamic Equalizer

Gain reduction
Indicates the actual gain reduction performed by the Dynamic EQ.

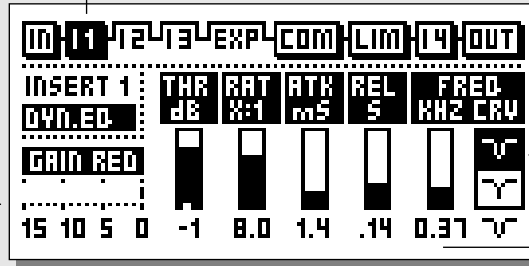

CURVE

Sets the frequency characteristics of the dynamic damping filter.

Frequency

Sets the working frequency of the Dyn-EQ.

Threshold, Ratio, Attack, Release

Stereo Enhancer

Added width
The actual added width.

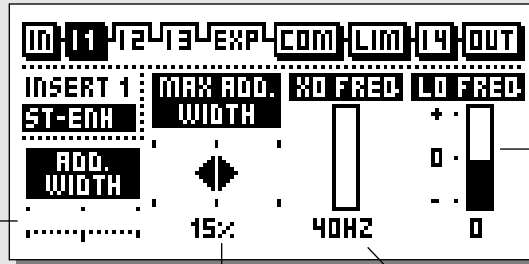

Low frequency adjust

Max added width

Adjusts the added width to the stereo perspective.

Cross-over frequency

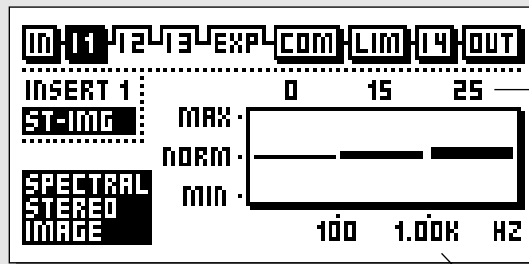

Image Width In %

Cross-over frequency

Dyn EQ

Threshold

When the Input level exceeds the Threshold, the Dynamic Equalizer will be activated.

Ratio

The Ratio of the gain reduction. When the Ratio is set to 4:1 it means that for every 4dB the defined frequency range rises above Threshold, the Output level of the specified frequency is increased by only 1dB.

Attack

The Attack time is the response time that the Dynamic EQ uses to reach the gain reduction specified by the Ratio parameter.

Example: If the Input signal increases to 4dB above Threshold with the Ratio set to 4:1 and the Attack set to 20ms, the Dynamic EQ will use 20ms to reach the gain reduction of 3dB.

Release

Release sets the fall-back time of the Dynamic EQ, after the signal drops below the Threshold.

Curve

Sets the bandwidth or low/high shelf setting of the range the Dynamic EQ should work in.

Stereo Enhance

With Stereo Enhance, you can enhance the stereo information of the signal. This function is especially useful when you are processing material with only a small amount of stereo perspective. By enhancing the stereo feeling of a signal with an excessive amount of mono information, listening fatigue can be prevented.

Please note that a Stereo Enhancer can not create stereo information, but only enhance existing stereo information.

Max added Width

With this parameter you set a limit for the Width you will allow to be added to the signal.

Added Width

Graphical illustration of the actual added width.

The actual possible added width depends on the stereo content of the signal. If the source material is 100% mono no stereo information can be added/enhanced.

Adding stereo perspective to the low frequency area will generally result in a less punchy and direct bass.

We have therefore included the Low Freq parameter with the following settings:

Lo Freq. 0 : No change.

Lo Freq. - : Collapse image at low frequencies.

Lo Freq. + : Add width at low frequencies.

Spectral Stereo Image

This function allows you to control the stereo width of your signal in three independent bands by adding or subtracting stereo information. Selecting values above 0 (Normal) will enhance the stereo information in the selected band, while values below 0 will reduce stereo information.

Use the PARAMETER keys to select the desired parameter and dial the ADJUST wheel to change values.

Cross-Over Frequencies

The minimum bandwidth for the Mid-band frequency area can be 1 octave.



Try enhancing the Stereo Image in the Mid and High band, while leaving the Low band untouched. This will widen the vocal and cymbal area while maintaining the punch from the bassdrum.

MAIN PAGE *Inserts 1-3*

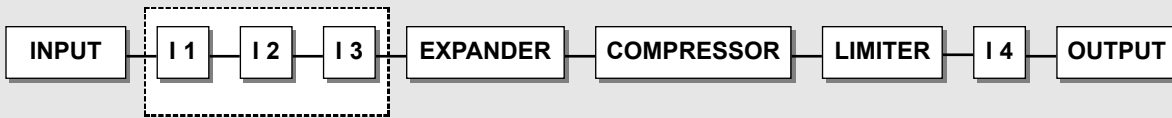

Normalizer

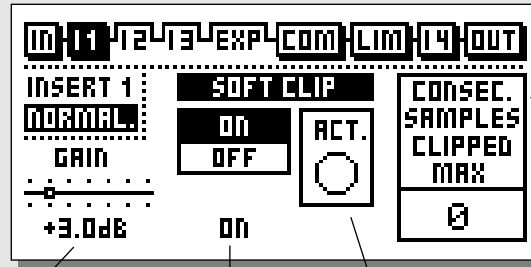

Normalizer Gain

On/off switch

Active

Will blink when active.

Consecutive samples clipped.

Counts the number of clipped samples within a 1 sec. time period.

MS Decoding

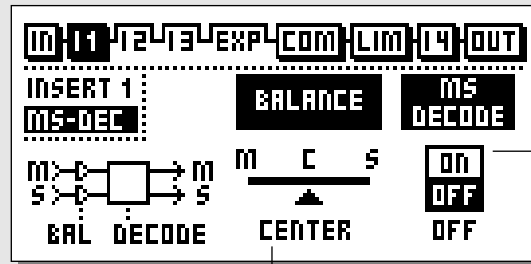

Mid-Side balance control

MS-Decode on/off switch.

MS Encoding

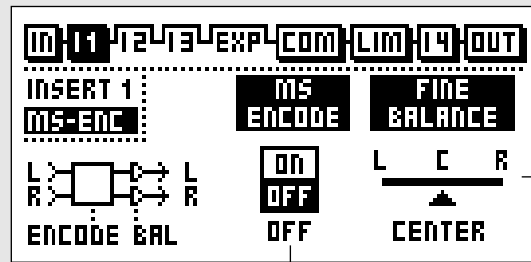

MS Encode on/off switch

Fine balance adjust

Normalizer

Optimization of the level of your material begins in the Normalizer. The objective here is to increase the gain to a level just below clipping. However, if the clips only occur occasionally, and only few samples are clipped per test interval, you do not necessarily have to reduce the gain of the Normalizer. The Normalizer monitors the signal within 1 second time periods.

Gain

The Normalizer is capable of gaining +18 dB. By increasing the Gain parameter the level of the signal gets closer to 0dBFS, and gaining the Input signal can therefore be perceived as a decreasement of the headroom.

On/off

On/off switching for the Softclipper.

Act. - Active

Will indicate (diode-style) when the Softclipper is activated.

Consecutive Samples Clipped

The Clip Counter indicates the maximum number of consecutive samples clipped within the last second.

MS Decoding/Encoding

MS (Mid/Side) miking technique uses a forward-facing directional mic and a side-facing bi-directional mic. MS recording offers very good stereo imaging with the added benefit of excellent mono compatibility. Through the electronic process of MS Encoding and Decoding, the two mic signals can be combined to create a stereo signal either before recording or on playback.

MS Decoding

MS Decoding will change a Mid/Side signal into a left/right signal.

Mid/Side Balance Control

The Balance control will allow you to change the relationship between the Mid/Side signals.

MS Decode on/off

On/off switch for the MS Decode Insert.

When MS-Decode is set to off the Fine balance parameter can be used for fine-tuning the left/right level balance.

MS Encoding

MS Encoding will change a regular left/right signal into a Mid/Side signal.

Fine Balance

The Fine Balance control will allow you to adjust the relationship between the Mid/Side signals.

MS Encode on/off

On/off switch for the MS Encode Insert.



Try lowering the Mid signal by a few dB. This is what is perceived as an enhancement of the overall Stereo image.

MAIN PAGE *Expander*

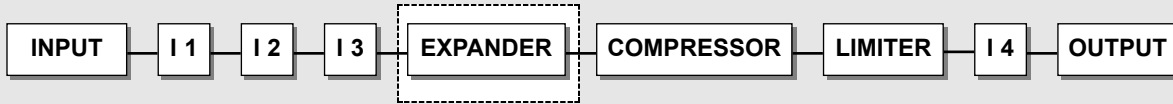

PAGE 1

Expander page select

Selected band indication
A dot indicates selected band or bands. By default all bands are selected, but you can adjust each band individually.

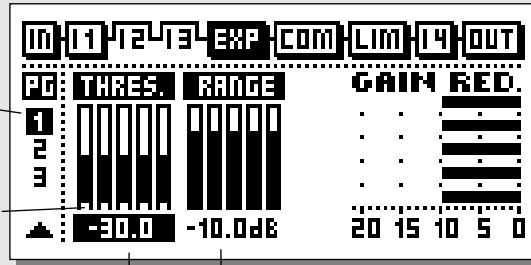

Threshold

Range

Adjusts the gain reduction of the 5 bands.

Gain Reduction

Shows the actual gain reduction on each of the 5 individual bands.

PAGE 2

The Edit guide

Arrow direction indicates whether the selected parameter value has been increased or decreased since last Recall. A dot indicates no changes.

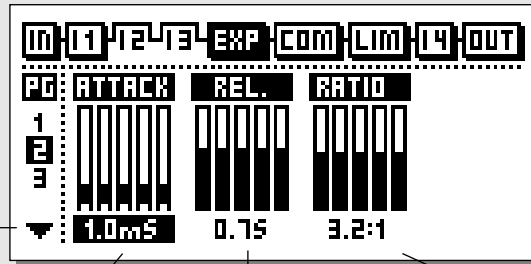

Attack time

Individual adjustment of Attack time on the five bands.

Release time

Individual adjustment of Release time on the five bands.

Ratio

Individual adjustment of Ratio on the five bands.

PAGE 3

**CROSS-OVER
FREQUENCY
PAGE**

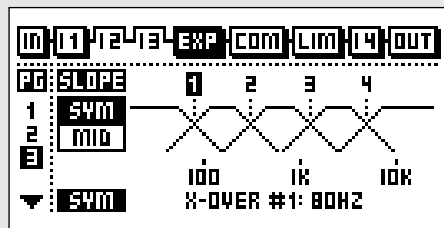

Expander

Expander Bypass

Press the gray BLOCK on/off key to bypass the Expander block.

Select EXP by pressing the BLOCK keys

Expander/Gates are often used to remove unwanted background noise. Both the Gate and the Expander perform what is called “Downward Expansion”. In general this means that below a certain Threshold the Input signal gain is reduced on the Output according to a specific Ratio. If for instance the Expander has a Ratio of 1:2, the Output is decreased with 2dB for every single dB the Input is decreased below Threshold.

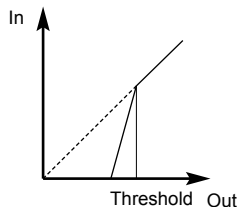

Basic Operation

- Press the PARAMETER keys to select parameter.
- Turn the ADJUST wheel to change values.
- Press the BAND keys to select between the five bands.
- Press the MENU keys to select Page1-3.

Page 1

Threshold

The Thresholds refer to “Ref. Level” in the Ref. Level menu. Individual bands can be selected by pressing the BAND keys.

Range

The Expander Range determines the maximum amount of gain reduction in each of the five bands in the Expander. E.g. when set to 6dB, the Expander will only reduce the Output by 6dB no matter how much the signal drops below Threshold. This enables you to use the Expander to simply reduce the signal below a certain Threshold instead of a complete shut-off.

Gain Reduction - Monitor

Graphical indication of the performed gain reduction in each of the five bands.

Page 2

Press MENU keys to select page 2

Attack

Attack is the time the Expander uses to bring the reduced signal to 1:1 when the signal exceeds the Threshold.

Release

The Release time is the time the Expander uses to reach the gain reduction specified by the Ratio parameter.

Ratio

The Ratio of the gain reduction. Use these parameters to adjust the Ratios of the five Expander bands. If the Ratio is set to 4:1 you will get a 4dB decrease on the Output signal for every 1dB the Input signal is decreased below Threshold.

Example: If the Input signal drops 4dB below Threshold, with the Ratio set to 1:4 and the Release time set to 20 ms, the DBMAX will use 20ms to reach a total gain reduction of 16dB.

Page 3 - Cross-over Menu

Press MENU keys to enter Page 3.

This page is common for the Compressor, Expander and Limiter. Please see the description on page 33.

The Edit Guide

The symbol in the lower left corner of the display is an Edit guide. This indicator will help you get back to the parameter values of the latest Recalled preset.

Example:

If you have been working on various parameters within a preset and would like to get, lets say, the original Ratios back without changing the Attack/Release times, simply select the Ratio parameters one by one and follow the Edit guide.

MAIN PAGE *Compressor*

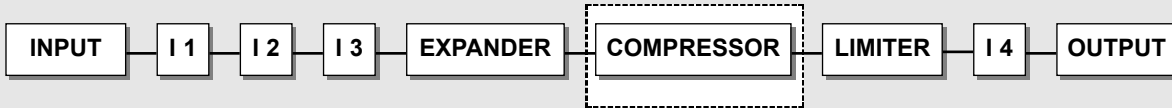

PAGE 1

Page select

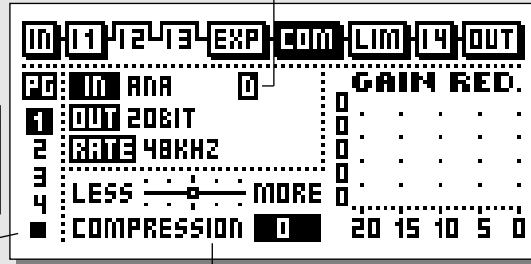

Flag indication

Gain Reduction
Shows the actual gain reduction on each of the 5 individual bands.

The Edit guide

Arrow direction indicates whether the parameter value has been increased or decreased since last Recall. A dot indicates no changes.

Less/More

Adjusts the intensity of the compression.

PAGE 2

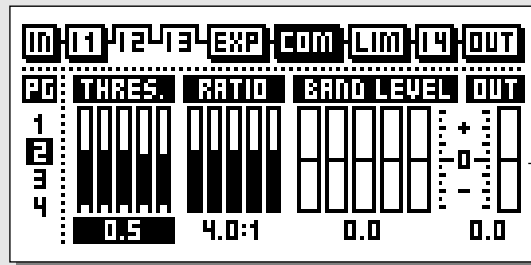

Out Level

Threshold

Individual control of Threshold of the five bands.

Ratio

Individual Ratio control for the five bands.

Band Level

Individual band level control for the five bands.

The Compressor

Select COM by pressing the BLOCK keys

Basic operation

- Press the PARAMETER keys to select parameter.
- Turn the ADJUST wheel to change values.
- Press the BAND keys to select between the five bands.
- Press the MENU keys to select between the 4 Compressor pages.

About the Compressor

The Compressor section of the DBMAX is divided into five bands. This means that you are able to compress five different frequency areas separately.

Based on a number of requests from initial users of the DBMAX, the automatic Make-Up gain has been removed, even though it partly still exists when using the Less/More handle.

Normally you should use the overall gain labeled OUT on Page 2 for Make-Up, and by having full control over the individual band levels there is now a very efficient way of adding post dynamics Equalization to your signal.

Dynamic Equalization can also be achieved simultaneously by using different Threshold and Ratio values in the different bands.

If you want to off-set the spectral balance (EQ) of low level signals, use the Band Levels in page no. 2 of the Compressor block.

If you want to off-set the spectral balance of high level signals, use the Threshold and Ratio in page no. 2 of the Compressor block.

Page 1

Less/More - Compression

An overall compressor intensity parameter. By using this function you can increase or decrease the intensity of compression while keeping the relationship between the Threshold and Band level parameters in accordance to the specified Ratio settings.

Threshold, Ratio and Band level parameters are found in page 2.

Flag indication

Different letters (flags) will occur on the In and Out line in the Compressor.

D - Delay time. (1-400ms) A “D” indicates that a Delay time has been added in the In block page 1 for the digital Inputs/Outputs. The first 10ms. works as a look ahead-delay to increase the precision of processing.

Note! Please refer to page 19 for additional info on delay thru the unit.

E - An “E” on the In-line indicates that Emphasis is present on the Input signal. The DBMAX automatically removes Emphasis present from the Input signal.

F - Input Hi-Cut/Lo-Cut filters active.
These filters are described on page 20.

S - Sample Rate converters on.

Gain Reduction

Graphical indication of the actual gain reduction performed by the Compressor.

Page 2

Press MENU keys to enter page 2

Threshold

Use the ADJUST wheel to change the Thresholds of the five bands.

The Thresholds refer to “Ref. Level” in the Ref. Level menu.

Ratio

Use these parameters to adjust the Ratios of the gain reduction in the five Compressor bands.

Band Level

The five band levels are used to adjust the spectral balance of the Compressor. Below the five bands, the level of the Mid band is displayed.

Out Level

With this parameter you can adjust the overall Output of the Compressor. This is the parameter you would use as make-up gain.

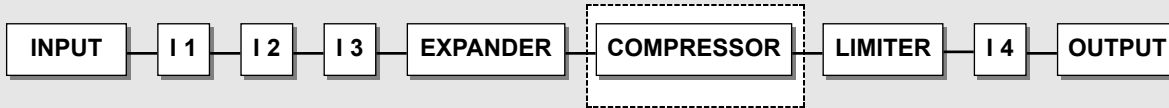

PAGE 3

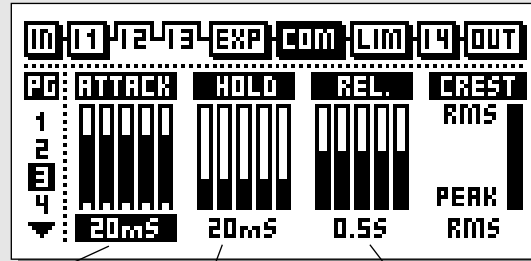

Attack
Individual Attack times for each of the five bands.

Hold
From 10-200ms.

Release
Individual Release times for each of the five bands.

Crest
This parameter determines whether the Compressor should react to peaks, RMS (average) or something in between.

PAGE 4

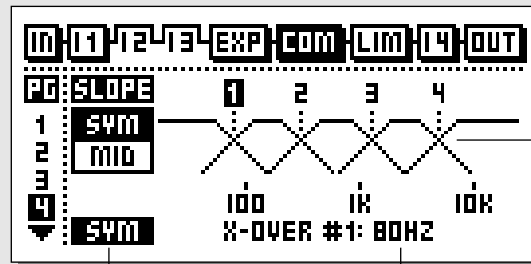

Slope type

Cross-over frequency

Cross-over point

Page 3

Press MENU keys to enter page 3.

Attack

The Attack time is the time the Compressor uses to reach the gain reduction specified by the Ratio parameter set in page 2. Use the ADJUST wheel to change the Attack time of the five bands.

Hold

After the signal has dropped below Threshold, the Hold parameter can be used to sustain the signal before it is released. The range is 10-200ms

Release

Release sets the fall-back time of the Compressor, after the signal drops below the Threshold.

Crest

This parameter determines whether the compressor should react to peaks, RMS (average), or something in between. For example if the Crest parameter is set at 6dB, the Compressor is reacting to RMS values and to peaks 6dB higher than the current RMS value.

Page 4 - Cross-over Menu

Press MENU keys to enter the Cross-over frequency page (Xovr)

Cross-over point 1-4

Cross-over frequencies may be altered on the last page of the Expander, Compressor and Limiter, but they are identical in all three blocks.

Two different filter structures are available:

- SYM with soft slopes
 - MID with higher order middle band focused filter slopes.
- The MID setting is designed specifically for low intermodulation between the bands, but if you want to emulate the TC Finalizer, you should use a 3-band structure and a SYM slope setting.

Number of Bands

On the Cross-over page, outer bands may be turned off by turning the cross-over points all the way up or down. When a structure of less than 5 bands is used, the bands are also removed from the graphic display.

Slope Types

Two different filter structures are available. SYM with soft slopes and MID with higher order middle band focused filter slopes.

Cross-over frequency

Sets the Cross-over frequency for the selected Cross-over point.

Cross-over point

With Cross-over points 1-4 you set the Cross-over points between the five bands in the dynamics section.

Note: The Cross-over points are common for the Compressor, Limiter and Expander.

Compressor Bypass

Press the gray BLOCK on/off key to bypass the Compressor section.

MAIN PAGE *Limiters*

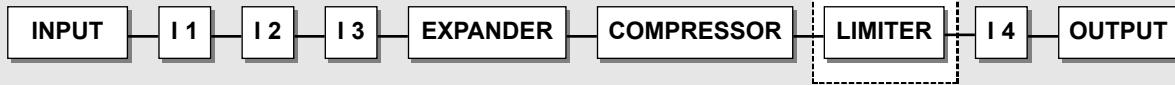

PAGE 1

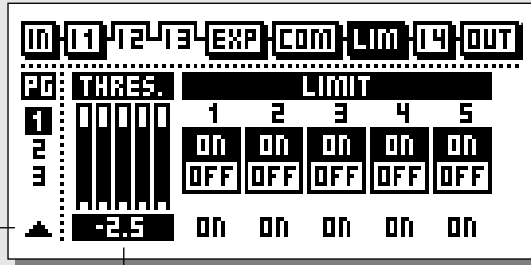

The Edit guide

Arrow direction indicates whether the parameter value has been increased or decreased since last Recall. A dot indicates no changes.

Limiters Threshold

Separate Threshold adjustment on each of the five bands.

Limit on/off

Bypass Limiter on individual bands.

PAGE 2

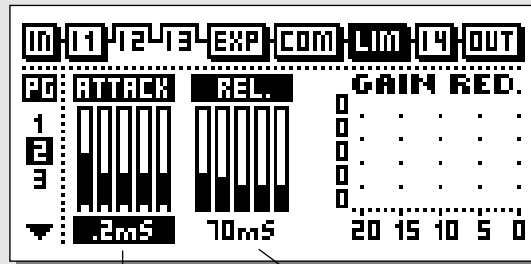

Attack Times

Individual Attack times for each of the five bands.

Release

Individual Release times for each of the five bands.

Gain Reduction

Shows the actual gain reduction on each of the 5 bands.

PAGE 3

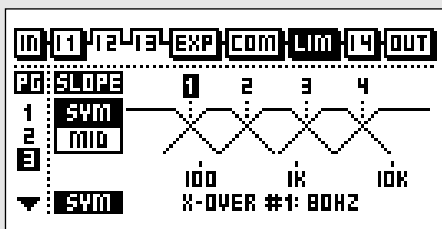

The Limiter

Select **LIM** by pressing the **BLOCK** keys

Basic operation

- Press the **PARAMETER** keys to select parameter.
- Turn the **ADJUST** wheel to change values.
- Press the **BAND** keys to select between the five bands.
- Press the **MENU** keys to select User/Xpert/Xover.

Page 1

Threshold

Use the **ADJUST** wheel to change the Thresholds of the five bands. The Thresholds refer to “Ref. Level” in the Ref. Level menu.

On/Off

Use these parameters to enable/disable the five Limiter bands.

Page 2

Press **MENU** keys to enter page2.

Attack

Use the **ADJUST** wheel to change the Attack time of the five bands.

Release

Use the **ADJUST** wheel to change the Release time of the five bands.

Page 3 - Cross-over Menu

Press **MENU** keys to enter the Cross-over frequency page (**Xovr**)

Cross-over point 1-4

Cross-over frequencies may be altered on the last page of the Expander, Compressor and Limiter, but they are identical in all three blocks.

Two different filter structures are available:

- **SYM** with soft slopes
 - **MID** with higher order middle band focused filter slopes.
- The **MID** setting is designed specifically for low intermodulation between the bands, but if you want to emulate the TC Finalizer, you should use a 3-band structure and a **SYM** slope setting.

Number of Bands

On the Cross-over page, outer bands may be turned off by turning the cross-over points all the way up or down.

When a structure of less than 5 bands is used, the bands are also removed from the graphic display.

Slope Types

Two different filter structures are available. **SYM** with soft slopes and **MID** with higher order middle band focused filter slopes.

Cross-over frequency

Sets the Cross-over frequency for the selected Cross-over point.

Cross-over point

With Cross-over points 1-4 you set the Cross-over points between the five bands in the dynamics section.

Note: The Cross-over points are common for the Compressor, Limiter and Expander.

Limiter Bypass

Press the gray **BLOCK** on/off key to bypass the Expander section.

MAIN PAGE *Post Dynamic Inserts*

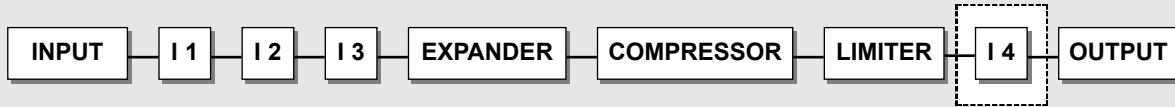

Transmission Limiter

Insert especially for Transmission or Transmission emulation.

Emphasis
 First letter - Analog
 Second letter - Digital
 Lin/Linear - when type is set to off.

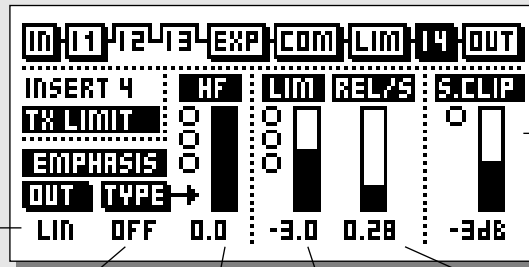

Softclipper

Emphasis type Dynamic
 50 μ , 75 μ or J.17
HF Limiter
Limiter Related to the Abs. Max peak setting.
Release time pr. second

Production Limiter

This Insert is normally used in Production and Continuity applications.

Gain Reduction
 Shows the actual gain reduction performed by the Production Limiter.

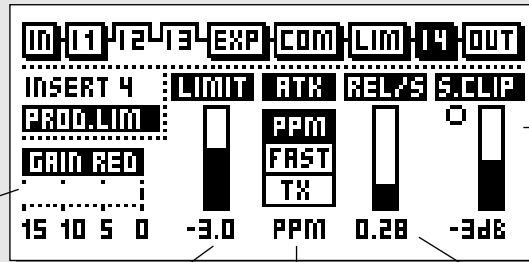

Softclipper

Limit
PPM Characteristics
Release time pr. second

Post Dynamics Inserts

Two different types of Limiters are available as post Dynamic Inserts in the I4 block. The dynamic Transmission Limiter and the static Production Limiter.

Transmission Limiter (TX)

Transmission Limiter with integrated Dynamic Emphasis and Soft Clip.

This Insert is normally used for Transmission or Transmission Emulation.

This Limiter is distortion cancelled and overshoot free.

- Activity of the Dynamic Limiter is shown by the on-screen “LEDs” in the HF section.
- Activity of the Soft Clipper is shown by the on-screen “LED” in the Softclip section.
- Activity of the Dynamic HF Limiter is shown by the on-screen “LEDs” in the Lim. section.

Emphasis

The DBMAX generates Emphasis of the type given at the Lim parameter (50 μ S, 75 μ S or J17).

You have different options for monitoring the Output signal regarding Emphasis.

Emphasis is handled according to this table:

Out

Linear : When type is set to “OFF”, no Emphasis is applied.
E-E : Emphasis on analog and digital Out.
E-D : Emphasis on analog Out, De-Emphasis on digital Out.
D-E : De-Emphasis on analog Out; Emphasis on digital Out.
D-D : De-Emphasis on both analog and digital Outputs.

Lim

The Threshold setting of the Limiter.

Rel/s

Sets the Release time in the Transmission Limiter. This is the fallback time for the Limiter after the signal drops below the Threshold.

HF-compensation

HF compensation is given by the Dynamic HF Limiter, ensuring optimum and distortion-free transmission.

Soft Clip

Soft Clip is related to Abs. Max Peak, which is set on the Ref. Level page. Activity of the Soft Clipper is shown by the on-screen “LED”.

Production Limiter

Production Limiter for use with analog DIN PPM meters or digital peak meters.

Gain Reduction

Shows the actual gain reductions performed by the Limiter.

Limit

The Threshold setting of the Limiter.

This Limiter is distortion cancelled and the Attack time may be calibrated to suit different environments:

ATK setting PPM:

Limiter characteristics to comply with analog PPM meters (DIN45406/IEC268-10, 10ms).

ATK setting FAST:

Limiter characteristics to comply with analog PPM meters with a fast response (1mS).

ATK setting TX:

Limiter characteristics to comply with digital meters (0mS).

Activity of the Dynamic Limiter is shown by the on-screen Gain Reduction meter.

Soft Clip

Soft Clip is related to Abs. Max Peak, which is set on the Ref. Level page. Activity of the Soft Clipper is shown by the on-screen “LED”.

MAIN PAGE *Output*

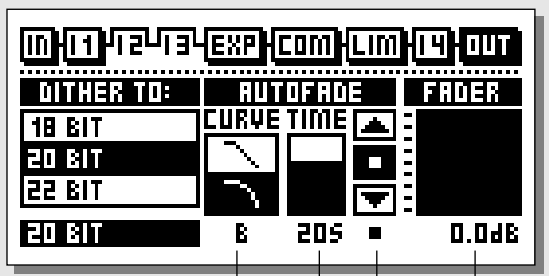
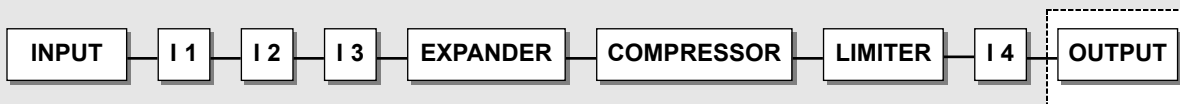

Select no. of bits dithered to:
8 bit
16 bit (default for S/PDIF)
18 bit
20 bit
22 bit
24 bit (default for AES)

FADE SECTION

CURVE sets the fade-out curve
TIME sets the fade-out time
FADE up/down/stop
LEVEL set fader level manually.

Note:

If an external fader is connected, all of the above parameters are disabled.

Select the **OUT** section in the Main page by pressing the **BLOCK** keys

Dither

The use of Dither is very important when interfacing digitally between audio equipment.

Every time resolution is changed from higher to lower, Dither (randomization) is necessary to minimize distortion for signals close to the noise floor. Even if the signal only has passed through a digital mixer, or a DBMAX, for adjustment of level, Dither should be applied if the succeeding device is of a lower resolution.

Dither in the DBMAX is only applied to the Main digital Outputs, and will not affect the analog Output signal.

Be sure to monitor the Output of the receiving device (e.g. post DAT), to hear the final result.

Dither Resolution

The Output resolution of the DBMAX is 24 bit. When the receiver of the DBMAX's signal has a lower resolution, Output Dither must be applied in the DBMAX to equal the resolution of the receiver.

Example: If the DBMAX is hooked up to a DAT via AES/EBU or S/PDIF interfacing, the Output Dither of the DBMAX should be set to 16 bit.

If the receiver is a HD editor capable of recording 24 bits, DBMAX Dither should be turned off.

If the receiver is a HD editor capable of recording 16 bits, but processing 24 bits all the way from the Input, Dither should normally be turned off at the DBMAX, leaving the dithering to be done within the HD editing system. If in doubt, try recording a low level sine wave through the DBMAX with the Dither switched off. For a 16 bit system, use a tone at e.g. -60dBFS. Play it back adding a fair amount of digital gain (e.g. 40dB), and listen for distortion. If distortion is heard, dither is not applied internally in the HD editor, and you have to do it with the DBMAX.

MAIN PAGE *Output*

Note: The Dither Resolution parameter is always reset when changing the primary Output.

Dither Type

In the DBMAX, TC Electronic has chosen to use TPDF Dither. This is the most user friendly type of Dither, and it does not restrict you from further downstream processing. You can Dither to 8, 16, 18, 20, 22 or 24 bits.

Auto Fade

The DBMAX is capable of auto-fades up to 60 seconds.

Select the Fade Curve type and the Fade time.

To start the fade, select the fade up/down parameter and turn the ADJUST wheel.

You also have the possibility of a manual fade, simply by selecting the Lev. parameter and turning the ADJUST wheel. The manual fade function can also be controlled by the optional TC Master Fader. Please see description at page 59.

Note: The Pedal Function in the Utility menu must be set to Fader for external control.

TOOLS *Flow*

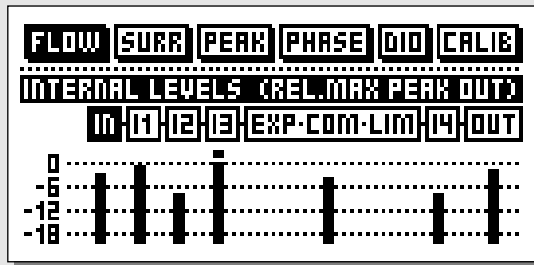

Internal levels (ppm)

Flow

In the Flow meter, you have five small peak meters, representing the level in the different sections of the DBMAX.

The Flow meter refers to absolute peak in the Ref. Levels menu.

When a block is overloading, use the parameter keys to select the current block and press OK for direct access.

TOOLS *Surround meter*

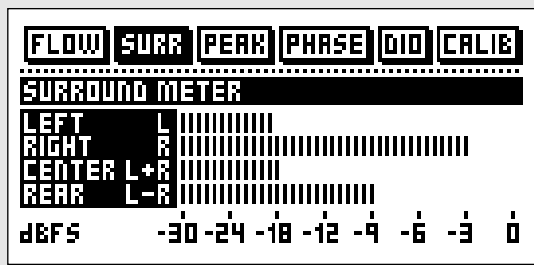

Surround meter

Four bars indicating the level of Left, Right, Left+Right, and Left-Right.

This will give you an impression of how much level you have present in a surround environment.

TOOLS Digital I/O - DIO

RECEIVED STATUS BITS

FLOW	SURR	PEAK	PHASE	DIO	CALIB
PAGE RECEIVED STATUSBITS:					
IN	PRE-EMPHASIS:		OFF		
OUT	SOURCE DEVICE:		DAT		
	AUDIO DATA:		16BIT		
	COPYRIGHT:		ONE COPY ONLY		

Pre-emphasis indicator: On/off

Source device: DAT, CD, mixer etc

Number of audio bits received

Copyright: None, One copy only, Infinite copies

FLOW	SURR	PEAK	PHASE	DIO	CALIB
PAGE COPY ENABLE STATUS BIT OUT					
IN	NO COPY		AES/EBU		
OUT	1 COPY		SPDIF		
	INFIN. COPY		FROM INPUT		
	INFIN. COPY		FROM INPUT		

Status bit info

Copy status

TOOLS Calibration Tone

FLOW	SURR	PEAK	PHASE	DIO	CALIB
CALIBRATION: PRESS OK TO START					
LEVEL:					
▶	dBREF: -12dB	dBu: -8dB	dBFS: -26dB		
TONE: 1000 HZ					
30	100	400	1000	10000	BESSEL 15000

Calibration tone

In Calibration you can choose between various test tones at definable level.

Level

Set the desired level of the test tone.

Tone

In

This display has various indicators describing the received digital signal.

Pre-emphasis

This parameter indicates whether the incoming signal is pre-emphasized or not.

Source device (Category code)

The device status of the received signal is shown in this indicator.

Audio data

The number of received audio bits is indicated here.

Copyright (Copy inhibit).

Status of the copybits.

Note: The above information can only be displayed if the information is present in the digital signal.

Out

In this display you set up how the DBMAX should output your material.

COPY ENABLE

Set the copyrights of your material:

- No copies
- 1 copy only
- Infinite number of copies.

Note: The copy protection is only valid with S/PDIF signals.

Status Bit Out

AES/EBU

When AES/EBU is selected the DBMAX will transmit its own professional set of status bits, meaning that any incoming ID will be lost. However, in order to take full advantage of the DBMAX's 24 bit resolution you should select AES/EBU to make sure that the receiving device after the DBMAX will accept all 24 bits.

S/PDIF

When S/PDIF is selected, the DBMAX will transmit its own consumer status bits out, meaning that any incoming ID will be lost. The DBMAX's S/PDIF Output carries up to 24 bits. Only the S/PDIF signal contains copy protection information.

From Input

When this setting is selected the DBMAX will transmit the same information as it received. However, you still have the possibility to change the copy status.

Calibration Tone

For optimal level handling in your signal chain, correct calibration of all meters is essential.

The DBMAX can be used to generate a calibration tone.

Level

dBref. refers to Ref. Level in the Ref. Level menu.

dBu refers to the In level in the Ref. Level menu.

dBFS refers to Digital fullscale.

The test tone level can never exceed 0 dBFS.

Tone

Select the desired testtone and press OK to start.

Press OK again to stop.

```

Utility
-----
DISPLAY:
▶ Viewing Angle: ———|———
TIMING CALCULATIONS:
Based On fps :      24
RS485 CTRL:
Prg. Change   :      Off
Address       :      1
SECURITY:
Security Lock : 
Your PIN-CODE :      0
MEMORY BACKUP:
RAM to CARD   : 
RAM Protect   : 
CARD to RAM   : 
RAM to MIDI   : 
MIDI to RAM   : 
PEDAL INPUT:
Function:      Bypass
ANALOG ADJUST
In Term Comp  :      on
In Fine L    :      0.0dB
In Fine R    :      0.0dB
Out Fine L   :      0.0dB
Out Fine R   :      0.0dB
    
```

Basic operation

- Use the MENU keys to select parameter.
- Use the ADJUST wheel to change values.

Display

Viewing Angle

Adjust for best contrast on the LCD display.

Timing Calculations

Based on fps.

The delay in the In page 1. of the In block is displayed in both frames pr second and milliseconds. The relationship between these parameters is setup in Timing Calculations.

For example – 25 frames per second means that 1 Frame equals 40 milliseconds.

RS 485 CTRL.

Remote change of presets is implemented in the DBMAX by using a RS485 controller. A PC or Macintosh computer may therefore easily control the system.

The command structure for a Program Change is
#AA,<cmd>,<value><CR>

AA is Unit Address number as set on the Utility page. cmd is command PRE for preset no., BYP for by-pass.

Pinout of the 5-way DIN connector:

(All three connectors carry the same RS485 I/O capability)

Data + : Pin no 3

Data - : Pin no 1

Common : Pin no 2 (Only on Thru and Output connectors)



The serial protocol is 9600, N, 8, 1.

This means 9,6 kbaud, no parity, 8 bit, 1 stop.

Security

To security-lock the DBMAX, press OK while this parameter is selected.

Lock

When locked, you will have to dial the PIN-code shown below to access the DBMAX.

Your PIN-code

Set your PIN-code for the security lock by dialing the ADJUST wheel (See page 36).

If you should forget your PIN-code, please enter the Reset page. This will release the DBMAX from the locked state. (You do not have to run any of the reset functions)

A keyboard lock facility is also provided. Press and hold the Help key for about 3 seconds, and all keys will be locked including the ADJUST wheel. The display will say *locked* in the top line. To unlock the keyboard, press Help again for about 3 seconds.

Memory Backup

RAM to Card

Insert a PC Card in the card slot and press OK. A backup of all RAM presets and User Ref. Levels setups will now be stored to the memory card.

RAM protect

If you accidentally select Card to RAM, when your intention was to select RAM to Card, the entire RAM will be overwritten. To avoid this unpleasant scenario you can use the RAM protect function. If this function is enabled you will not be allowed to overwrite the RAM bank.

Card to RAM

Insert the PC Card containing your presets and press OK. All RAM presets and User Ref. Levels setups stored on the card will now be transmitted to the DBMAX

Warning:

This action will destroy all existing RAM presets of the DBMAX.

RAM to MIDI

Connect your DBMAX's MIDI Output to another DBMAX, a sequencer or any other MIDI recording device. Press OK and the DBMAX will perform a MIDI bulk dump of all RAM presets.

MIDI to RAM

Connect the storing device to the DBMAX's MIDI Input and press OK. The DBMAX is now ready to receive a MIDI bulk dump containing RAM presets.

In Term Comp

With additional hardware modification, DBMax can be used in 600 ohm terminated environments. Software auto-detects if hardware modification has been carried out. If hardware has not been modified, "---" is shown on screen at line "In Term Comp". If hardware has been modified and "on" is selected, "dBm" replaces "dBu" for on-screen level measure.

For information on how to achieve this modification please contact your local TC distributor or authorized TC Electronic Service center.

Note: New DBMaxes dispatched from TC are not hardware modified unless requested.

Pedal Input

Function

Select between: External Fader/Fade up-down/Bypass/Preset.

Analog Adjust

In Fine L

Fine adjust for the Left channel Input. This parameter may be trimmed in 0.1dB steps.

In Fine R

Fine adjust for the Right channel Input. This parameter may be trimmed in 0.1dB steps.

Out Fine L

Fine adjust for the Left channel Output. This parameter may be trimmed in 0.1dB steps.

Out Fine R

Fine adjust for the Right channel Output. This parameter may be trimmed in 0.1dB steps.

RESET PAGE

Store and load your own default settings

Enter User data page

Reset system parameters

Clear all user presets

Test Programs

```
RESET
-----
▶LOAD USER DEFAULT  OK
STORE USER DEF.     OK
SET USER NAME       OK
RESET SYS PARAM.    OK
CLEAR ALL PRESETS   OK
RUN TEST PROGRAM    OK
```

Type your name here
and your phone number

```
USER DATA
-----
▶NAME: Albert E
PHONE: 123456789
C  A B C D E F G H I J K L M N
P  O P Q R S T U V W X Y Z [ ]
M  4 5 6 7 8 9 0 - + : < ▶ DONE
```

DONE

Confirms/enters the printed data

Basic operation

- Enter the Reset page by holding the BYPASS key while power-up.
- Press and hold the BYPASS key while powering up.
- Move the cursor using the MENU keys and press OK to select reset type.

Load User Default

This will reset all system parameters back to a default setup made by you (see Store User Def.). This reset will NOT delete the user presets of the DBMAX.

Auto-Load User Default

User defaults (= all settings) can be recalled on every power up of the machine automatically by selecting the AUTO load function. To activate the Auto Load Function:

- Place cursor a “Load User Default”
- Turn ADJUST wheel to select “Auto”.

With Auto-Load enabled the machine can be powered up in a completely known state on every power-up.

Store User Def.

When you have a perfect setup of your DBMAX, you are able to store this as your own default setup. This function is very useful for example when you have finished a special production and want to go back to normal. To Store settings using this the function:

- In “normal operation mode”, not the Reset page, setup all your preferred settings (Preset, Ref. Levels, Utility parameters, Sync etc.).

To access the Store facility you must enter the Reset page:

- Power down the machine - all settings are kept.
- Power up the machine holding the BYPASS key.
- Select "Store User Def" and press OK.

The User Default includes all system parameters.

Set User Name and Phone number

Store your name and phone number in the DBMAX.

- Press OK to access the user data menu.
- Use the MENU keys to move cursor between the name and phone-number lines.
- Use the ADJUST wheel to select letters and confirm each letter with the OK key.
- Select DONE and press OK to end this operation.

Your name and phone number will be displayed during power-up.

RESET PAGE

Reset System Parameters

This will reset all system parameters back to the factory default. This reset will NOT delete the user presets of the DBMAX.

Clear all Presets

This will clear all Ram presets.

Run Test Program

Activates the built in Test Program.

Auto-load of Default Settings

User defaults (= all settings) can be recalled on every power up of the machine by selecting the AUTO load function in the Reset menu. The Reset menu is found by holding the BYPASS key during power-up.

Auto-load enables the machine to be in a completely known state on every power-up.

To use the function, first adjust all settings (Preset, Ref. Levels, Utility parameters, Sync etc.) to what you want as Default. Then:

- Power down the machine.
- Power up the machine holding the BYPASS key.
- Select "STORE USER DEF" and press OK.

To Auto-load settings on every power-up, select "AUTO" in the "LOAD USER DEFAULT" line.

WIZARD

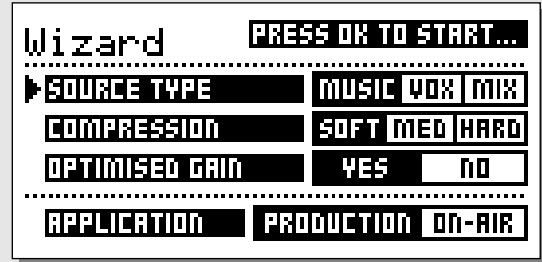

The Wizard

To get an easy starting point for your own sound-tailoring you may invoke the Wizard function.

Press the WIZARD key and answer a few questions.

Source type

- Select MUSIC if the source material primarily is music.
- Select VOX if the source material primarily is vocals.
- Select MIX when the vocals and the music in your mix is evenly weighted.

Compression

- Soft program types would be slowly changing signals as found in some Classical music, New age, Ambient etc.
- Medium program types would be normal Film, Radio and TV work, Country and Folk music, AOR types of music.
- Hard program types would be Commercials, Aggressive Pop and Rock music.

Optimized gain

Select "YES" if you want the DBMAX to automatically adjust the Normalizer level.

Application

Select the application type. Choose between Production or On-Air.

The Wizard settings may later be modified (e.g. by adding AGC, EQ etc.) and stored to a RAM location or PCMCIA card.

APPENDIX - *Troubleshooting*

You press the POWER switch but there is no light

- The POWER switch on the rear panel is switched off.

The Input PPM meters don't peak out

- You are using analog Inputs, but the Input selector in the I/O menu is set to digital in.
- The analog Input level is set too low.

No sound through the DBMAX

- You are using analog Inputs, but the Input selector in the I/O menu is set to digital in.

You cannot turn the power off

- Hold the POWER switch pressed for at least 3 seconds.

You hear a lot of noise on the DBMAX Output

- 8 bit dither is on, go to the out section and select a suitable dither.

APPENDIX - *Self test*

Press the BYPASS key while powering up to access the self-test and select “ RUN TEST PROGRAM”.

Use the ADJUST wheel to scroll through the different self tests.

Key test

Select Key test by pressing OK.

The keys must be pressed in the order they are requested by the DBMAX to pass the test.

Press the HELP key to exit test.

ADJUST wheel test

Select ADJUST wheel test by pressing OK.

Turn the ADJUST wheel to 30 and back to 0 to pass test.

Press the HELP key to exit test.

LED test

Select LED test by pressing OK.

Turn ADJUST wheel to test the LEDs. The test is “ok” when all LEDs are lit.

Press the HELP key to exit test.

Display test

Select Display test by pressing OK.

Press OK to check that all pixels are lit. Press any key to leave the pixel test.

Press OK key again to exit test.

Analog I/O test

Select analog I/O test by pressing OK.

Connect both DBMAX analog Outputs to the DBMAX analog Inputs, left to left, right to right, and press OK.

Use balanced cables.

PPM must show -12 dB to pass test.

Press the HELP key to exit test.

Digital I/O test

Select digital I/O test by pressing OK.

Connect the DBMAX’s AES/EBU Output to the DBMAX’s AES/EBU Input and press OK.

Connect the DBMAX’s S/PDIF Output to the DBMAX’s S/PDIF Input and press OK.

Connect the DBMAX’s ADAT Output to the DBMAX’s ADAT Input and press OK.

PPM must show 0dB to pass test.

Press the HELP key again to exit test.

MIDI I/O test

Select MIDI I/O test by pressing OK.

Connect MIDI Out to MIDI In.

Prg. change 1-128 is send out on MIDI thru. Connect this socket to a MIDI compatible device and confirm the Prg. changes.

Press the HELP key to exit test.

Pedal test

Select Pedal test by pressing OK.

Connect a momentary pedal to the pedal socket.

When pressing the pedal, the result should be OK.

When released, the result should be NOT OK.

Press the HELP key to exit test.

PCMCIA Card test

Select PC Card test by pressing OK.

Insert PC Card.

Note that all data on the PC Card will be destroyed.

Press OK to test.

Result reads:

- Low battery - Time to change battery in your PC Card.
- Not Ok - Try the test using another PCMCIA card.

Press the HELP key to exit test.

Battery test

Select Battery test by pressing OK.

Confirm that result is OK.

Press the HELP key to exit test.

System test

Select System test by pressing OK.

Confirm that result is OK.

Result reads:

- EEPROM Not OK - The unit will most likely work ok, the message is for service matters only.
- DSP Not OK - Contact your local dealer.

Press the HELP key to exit test.

Power Off - On to start standard software.

Service note

In case of the unlikely event that the unit needs to be sent in for service, please use the original box AND an outer box.

TECHNICAL SPECIFICATIONS

Digital Inputs and Outputs

Connectors:	XLR (AES/EBU) RCA Phono (S/PDIF)
Formats:	AES/EBU (24 bit), S/PDIF (20 bit), EIAJ CP-340, IEC 958
Output Dither:	HPF TPDF dither 8-22 bit
Word Clock Input:	BNC, 75 Ohm, 0.6 to 10 Vpp
Sample Rates:	32 kHz, 44.1 kHz, 48 kHz
Processing Delay:	0.5 ms @ 48 kHz
Frequency Response DIO:	DC to 23.9 kHz \pm 0.01 dB @ 48 kHz

Sample Rate Conversion

Type:	Asynchronous
Dynamic Range:	120 dB
THD+N:	-106 dB 44.1 to 48 kHz @ 1 kHz, -2 dBFS
Input Rate Range:	31 kHz to 49 kHz

Analog Inputs

Connectors:	XLR balanced (pin 2 hot)
Impedance:	20 kOhm (balanced)
Max. Input Level:	+27 dBu (balanced)
Min Input Level (for 0 dBFS):	-4 dBu (balanced)
A to D Conversion:	24 bit (1 bit, 128 times oversampling)
A to D Delay:	0.8 ms @ 48 kHz
Dynamic Range:	>103 dB (unweighted), >106 dB(A)
THD:	-95 dB (0.0018 %) @ 1 kHz, -6 dBFS (FS @ +18 dBu)
Frequency Response:	10 Hz to 20 kHz: +0/-0.2 dB
Crosstalk:	<-80 dB, 10 Hz to 20 kHz typical -100 dB @ 1 kHz

Analog Outputs

Connectors:	XLR balanced (pin 2 hot)
By-pass:	Through relay
Impedance:	40 Ohm (balanced)
Max. Output Level:	+26 dBu (balanced)
Full Scale Output Range:	-4 dBu to +26 dBu (balanced)
D to A Conversion:	24 bit (1 bit, 128 times oversampling)
D to A Delay:	0.57 ms @ 48 kHz
Dynamic Range:	>100 dB (unweighted), >104 dB(A)
THD:	-86 dB (0.005 %) @ 1 kHz, -6 dBFS (FS @ +18 dBu)
Frequency Response:	10 Hz to 20 kHz: +0/-0.5 dB
Crosstalk:	<-60 dB, 10 Hz to 20 kHz typical -90 dB @ 1 kHz

EMC

Complies with:	EN 55103-1 and EN 55103-2 FCC part 15, Class B CISPR 22, Class B
----------------	--

Safety

Certified to:	IEC 65, EN 60065, UL 1419 and CSA E65
---------------	---------------------------------------

Environment

Operating Temperature:	32° F to 122° F (0° C to 50° C)
Storage Temperature:	-22° F to 167° F (-30° C to 70° C)
Humidity:	Max. 90% non-condensing

PCMCIA Interface

Connector:	PC Card, 68 pin type 1 cards
Standards:	PCMCIA 2.0, JEIDA 4.0
Card Format:	Supports up to 2 MB SRAM

Control Interface

RS485/RS422:	5 Pin DIN
MIDI:	In/Out/Through: 5 Pin DIN
GPI, Pedal, Fader:	1/4 inch phone jack

General

Finish:	Anodized aluminum face and top plate Plated and painted steel chassis
LCD:	56 x 128 dot graphic LCD-display
Dimensions:	19" x 1.75" x 8.2" (483 x 44 x 208 mm)
Weight:	5.2 lb. (2.35 kg)
Mains Voltage:	100 to 240 VAC, 50 to 60 Hz (auto-select)
Power Consumption:	<20 W
Backup Battery Life:	>10 years
Warranty, Parts and labor:	1 year

Technical Specifications are subject to change without notice !

The unit is shipped with a number of factory presets identified as ROM on the Recall page.

Presets are only meant as starting points. We urge you to tailor the sound to the application or profile you want. With a couple of changes, On-Air presets may be adopted for production or mastering or vice versa.

Before having a tour through the presets, first load a proper level setup in the Ref. Levels page.

For permanent installations also trim analog Outputs in 0.1dB increments to achieve precise in situ interfacing.

Film and Post Production

For Film and Post Production applications you should first go to the Ref. Levels page and load a suitable setup, e.g. EBU Broadcast or Film Mastering. The Delay on Input page no. 1 should be set between 3 and 10 ms and turned ON.

Remember to setup appropriate Dither on the Out page if you use digital Outputs. The receiving device will have a preference for a given resolution from the DBMAX.

For mastering applications, the DBMAX can give you a 100% overshoot free overload protection satisfying either analog or digital metering standards. You may also simultaneously level maximize your sound.

Apart from the many Limiting and Compressor/Limiter mastering presets, some production presets are meant for recording. In Film Production old noise reduction systems are sometimes used for dialog clean-up. In the DBMAX we've emulated some of the machines on presets like CleanUp 100% and CleanUp Cat43. Also a couple of special effects are available.

If you want to offset the spectral balance (Eq) of low level signals, use the Band Levels on page no. 2 of the Compressor block. If you want to off-set the spectral balance of high level signals, use the Threshold and Ratio on page no. 2 of the Compressor block.

Film and CD Mastering

For Film and Post Production applications you should first go to the REF LEVELS page and load a suitable setup, e.g. EBU Broadcast, Film Mastering or CD Mastering. Also check that the Hi-Cut filters on Input page no. 2 are not activated, and the

Delay on Input page no. 1 is set between 3 and 10 ms and turned ON.

Remember to setup appropriate Dither on the Out page if you use digital Outputs. The receiving device will have a preference for a given resolution from the DBMAX.

For final limiting at the Output, the Production Limiter would typically be used with a PPM response for Film Mastering and a TX response for CD Mastering. By balancing the Limiter Threshold and the Soft Clipper, different results may be obtained. To create a good Mono master from a stereo source, try using the EBU90**Mono* preset.

To adjust the Stereo Width you may use the MS Encoder + MS Decoder in that sequence and offset the M/S balance. Gain should be made up with e.g. the Normalizer.

If you want to offset the spectral balance (Eq) of low level signals, use the Band Levels on page no. 2 of the Compressor block. If you want to offset the spectral balance of high level signals, use the Threshold and Ratio on page no. 2 of the Compressor block.

Broadcast Continuity

For Continuity applications you should first go to the Ref. Levels page and load a suitable setup, e.g. EBU Broadcast. The Delay on Input page no. 1 should be set between 2 and 3 mS and turned ON.

You may wish to add further delay for link compensation etc. Use the same Delay control on this page, but generally avoid reducing it to less than 1ms. The Delay is also shown in Frames on the Input page. The calculation is based on the fps. setting in the Utility page.

Remember to setup appropriate Dither on the Out page if you use digital Outputs. The receiving device will have a preference for a given resolution from the DBMAX.

As a starting point for a unity gain limiter in an EBU environment, first load the EBU Broadcast setup, then the EBU Limiter preset.

The 5-band Limiter will provide full Output protection for Input signals up to 0dBFS or +18dBu.

As an example, distortion figures for digital I/O applications are

given for the EBU Limiter Preset running the EBU Broadcast setup.

THD+N@40Hz: -124dB for -18dBFS in, -96dB for -9dBFS in, -90dB for 0dBFS in.

THD+N@1kHz: -124dB for -18dBFS in, -99dB for -9dBFS in, -96dB for 0dBFS in.

THD+N@20kHz: -124dB for -18dBFS in, -124dB for -9dBFS in, -122dB for 0dBFS in.

Mono generation is accomplished by the EBU 90 degree Mono preset. You may build additional inserts like AGC, EQ, De-esser etc. into the presets.

All presets exist in two versions: The On-Air versions have brick-wall Output peak handling set at Abs. Peak Max. The Production versions have DIN45406 peak handling set at Abs. Peak Max. -3dB.

If you want to off-set the spectral balance (Eq) of low level signals, use the Band Levels on page no. 2 of the Compressor block. If you want to off-set the spectral balance of high level signals, use the Threshold and Ratio on page no. 2 of the Compressor block.

Transmission

For Transmission applications you should first go to the REF LEVELS page and load a suitable setup, e.g. EBU Broadcast or digital TX. Also check that the Hi-Cut filter on Input page no. 2 are positioned correctly, and the Delay on Input page no. 1 is set between 2 and 3 ms and turned ON.

For DAB applications the Hi-Cut filter should be turned off. For NICAM applications normally only turn on the Lo-Cut filter at the In page no. 1.

For FM transmission we recommend setting the Lo-Cut filter between 20 and 40Hz. If you use a digital composite generator, normally the DBMAX should handle Emphasis generation, HF Limiting and Soft Clipping to maximize the signal and avoid overshoots. Emphasis should be generated as a combination of tuning band 3-5 Threshold/Ratio settings in the Compressor and the TX Limiter in Insert 4.

FM transmission is by nature a trade-off between Level, HF amount and Distortion. If you insist on a high sound level, please bear in mind that an overly clipped or multi-band manipulated signal may easily create listening fatigue.

It may prove wiser to back off a couple of dB in order to get a cleaner and brighter sound.

When you use the built-in Dynamic Emphasis capability in the DBMAX, please observe that Emphasis is NOT indicated on the digital Outputs, because the AES/EBU specification has no definition of 50 μ s or 75 μ s Emphasis.

For a digital transmission like in a NICAM or DAB environment, setup appropriate Dither on the Out page. The receiving device will have a preference for a given resolution from the DBMAX.

For redundancy in Transmission, an Input relay by-passes the unit in event of power failure.

We are currently evaluating different digital stereo generators in order to match the characteristics of the reconstruction filter in selected devices.

If you have specific requirements or information about your setup, feel free to contact TC Electronic at info@tcelectronic.com

The DBMAX for mastering is a very potent tool. Please be careful not to overmaximize your source material just because you can.

Listening fatigue is typically the consequence of a very dense sound image.

AES/EBU

Professional digital in/out standard, using balanced XLR cables. The AES/EBU format can output 24 bit 96kHz.

S/PDIF

Consumer digital in/out standard, using coaxial phono-type cables. This format can generally output 20 bit 48kHz. TC products can output all 24 bits on S/PDIF.

Tos-link

Also called optical S/PDIF. Two channels of 24 bit, 96kHz can be transferred with this format.

ADAT/TDIFF

Format capable of transferring 8 channels of 24 bit 48kHz, using optical cables.

Brickwall type limiter

A type of limiter that allows absolutely no signal above threshold.

Bits & Bytes

1 bit is the smallest unit for information in the digital world. Its value can be 0 or 1 or you could say on/off. 1 byte=8 bit.

Compressor Overshoot

When slow Attack times are used overshoots might occur. This causes an unwanted click/distortion and. To prevent compressor overshoots you can use a brickwall type limiter.

Cross-over point

Splitpoint indicating where the different bands begins/stops working.

dBFS

dB full scale. 0dBFS is the absolute max in the digital world. Any signal above 0dBFS will cause serious unwanted distortion.

dBu

Measuring unit in the analog world.
0dBu=0,775V in 600ohm

dBv

Measuring unit in the analog world.
0dBv is 1V in 600 ohm.

De-essing

An algorithm that removes unwanted “esses” or sibilance from vocal material.

Dither

Going from one type of bit resolution to a lower, e.g. from 24 bit to 16 bit, you actually lose 8 bits of information. The process of cutting off bits is called truncation and it introduces digital distortion of low level signals, due to the lack of complete signal information. To compensate for this, dither must be applied. Dither is a small amount of filtered noise that generates randomization at the noise floor ensuring a less distorted low level signal. Dithering is relevant only on digital Outputs and it is always the receiving device that determines the number of bits you must dither to. A DAT or CDR recorder should normally be Dithered to 16 bit.

House Clock

A separate piece of equipment used only to generate a common standard clock keeping all the attached digital equipment in sync.

Master Clock

If you don't use a separate House Clock you can use most digital units for the same purpose. In this case the unit you sync to is called the Master Clock.

Make up gain

To optimize the output gain and energy in your material auto Make-Up gain can be used to gain the compressed band automatically.

Sample Rate

The quality of sound depends on how precise you can measure the analog signal. Measuring is done by taking “pictures” of the wave at a given rate: The Sample Rate. Since you need two points to define a sinus curve, the maximum frequency that can be successfully reproduced is the Sample Rate divided by two. E.g. the max frequency that can be successfully reproduced with a Sample Rate of 48kHz is 24kHz.

De-essing

An algorithm that removes unwanted “esses” or sibilance from vocal material.

System Exclusive MIDI Commands

Device-dependent MIDI commands, normally used for remote controlling machines.

Pre-emphasis

Pre-emphasis is used during broadcast to boost the high frequency area. The receiving device compensates by attenuating the same frequency area.

APPENDIX *Soldering instructions*

MIDI Cable

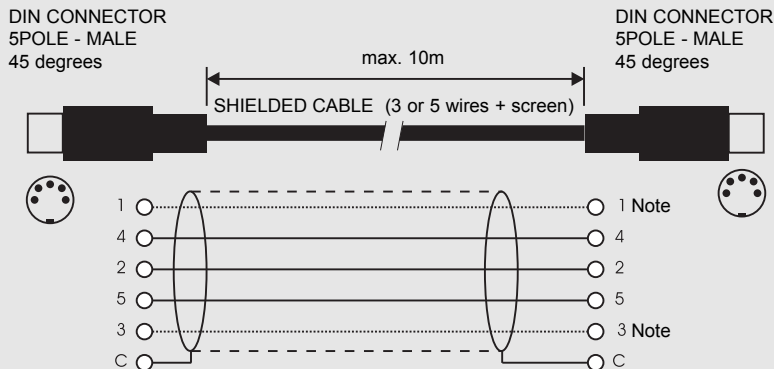

NOTE!

On TC units with RS485 interface pins 1 and 3 on the DIN connectors are reserved for RS485 connection. Therefore, if you are connecting the unit to other equipment that use these pins, please make sure to use 3-wire standard MIDI type cable (not a five wire MIDI-PLUS type).

Pedal Cable

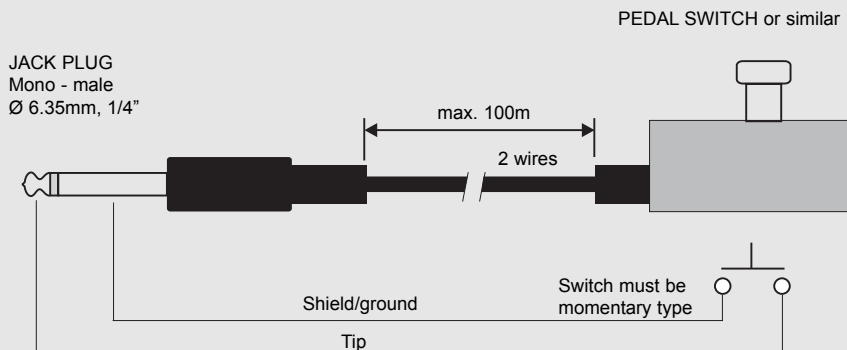

Fader Cable

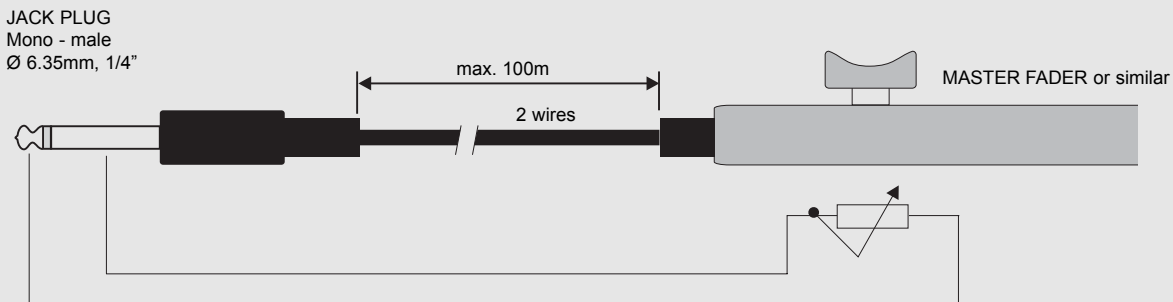

APPENDIX *Soldering instructions*

XLR - XLR

Pin 1 - Pin 1 (Ground)
Pin 2 - Pin 2 (Hot)
Pin 3 - Pin 3 (Cold)



Jack (unbalanced) - XLR

Sleeve - Pin 1 (Ground)
Tip - Pin 2 (Hot)
Sleeve - Pin 3 (Cold)

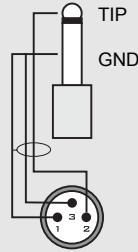

Jack (balanced) - XLR

Sleeve - Pin 1 (Ground)
Tip - Pin 2 (Hot)
Ring - Pin 3 (Cold)

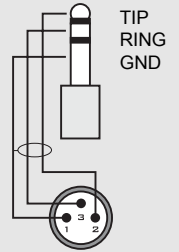

PRESET LIST

Presets for Mastering and Production

No	Name	Main Function	Typical Level Setup	Applications
1	EBU Limiter	Limiter, Europe	EBU Broadcast	OB, PP
2	NAB Limiter	Brickwall Limiter, US	NAB Broadcast	OB, PP
3	EBU Comp & Lim	Optimize & Limit, Europe	EBU Broadcast	OB, PP
4	NAB Comp & Lim	Optimize & Limit, US	NAB Broadcast	OB, PP
5	EBU Mix Pilot	Mix Assist & Limit, Europe	EBU Broadcast	OB, PP
6	NAB Mix Pilot	Mix Assist & Limit, US	NAB Broadcast	OB, PP
7	CD Master	Optimize & Limit	CD Mastering	CD
8	Film Limit	Limiter	Film Mastering	MA
9	Film to Video	Low level boost & Limit	NAB Broadcast, NAB DTV	PP, BC
10	Finalizer	Optimize & Limit	CD Mastering	CD, PP
11	Finalizer 2Band	Optimize & Limit	CD Mastering	CD, PP
12	Finalizer 5Band	Optimize & Limit	CD Mastering	CD, PP
13	Trailer	Optimize & Limit	NAB Broadcast	PP, MA
14	Commercial	Optimize & Limit	NAB Broadcast	PP
15	Propaganda	Optimize & Limit	NAB Broadcast	PP
16	NICAM ProdLim	Limiter	EBU Broadcast	PP
17	De-Esser	Voice Processor	NAB Broadcast	PP
18	De-Wow	Voice Processor	NAB Broadcast	PP
19	CleanUp Cat43	Noise Removal	CD Mastering	PP

Presets for Webcast and Web Authoring

No	Name	Main Function	Typical Level Setup	Applications
20	EBU Webcast	Codec optimize, Europe	EBU Webcast	WC
21	NAB Webcast	Codec optimize, US	NAB Webcast	WC
22	EBU WebMax	Codec loud, Europe	EBU Webcast	WC
23	NAB WebMax	Codec loud, US	NAB Webcast	WC
24	EBU WebTx Mono	Mono web TX, Europe	EBU Webcast	WC
25	NAB WebTx Mono	Mono web TX, US	NAB Webcast	WC
26	EBU WebTx 128k	Restr. BW web TX, Europe	EBU Webcast	WC
27	NAB WebTx 128k	Restr. BW web TX, US	NAB Webcast	WC
28	EBU WebTx 56k	Restr. BW web TX, EU	EBU Webcast	WC
29	NAB WebTx 56k	Restr. BW web TX, US	NAB Webcast	WC

Presets for Digital Television and Linking

No	Name	Main Function	Typical Level Setup	Applications
30	EBU Tx Limit	Brickwall Limiter, Europe	EBU Broadcast	BC, DL, DT
31	NAB Tx Limit	Brickwall Limiter, US	NAB Broadcast	BC, DL, DT
32	EBU Tx AGC	Optimize & Limit, Europe	EBU Broadcast	BC, DL, DT
33	NAB Tx AGC	Optimize & Limit, US	NAB Broadcast	BC, DL, DT
34	EBU Com. DTV	Opti level, width & Limit	EBU Broadcast	BC, DL, DT
35	NAB Com. DTV	Opti level, width & Limit	NAB Broadcast	BC, DL, DT
36	EBU Link	Wide range Opti & Limit	EBU Broadcast	DL, WC
37	NAB Link	Wide range Opti & Limit	NAB Broadcast	DL, WC
38	EBU OptiLink	Wide range Opti & Limit	EBU Broadcast	DL, WC
39	NAB OptiLink	Wide range Opti & Limit	NAB Broadcast	DL, WC

PRESET LIST

Presets for Digital and FM Radio

No	Name	Main Function	Typical Level Setup	Applications
40	DAB	Optimize & Limit	EBU Broadcast	BC, DR
41	DAB <AGC>	Optimize & Limit	EBU Broadcast	BC, DR
42	Classical DAB	Optimize & Limit	EBU Broadcast	BC, DR
43	FM Subtle	Opti level, width & Limit	FM Generator	FM, RO, WC
44	FM Wide	Opti level, width & Limit	FM Generator	FM, RO, WC
45	FM Moderate	Opti level, width & Limit	FM Generator	FM, RO, WC
46	FM Power ISPA	Opti level, width & Limit	FM Generator	FM, RO, WC
47	FM Energy	Opti level, width & Limit	FM Generator	FM, RO, WC
48	Studio Outlet	Optimize & Limit	Studio Outlet	RO
49	Energy Outlet	Optimize & Limit	Studio Outlet	RO

Presets for OB and Live Broadcast

No	Name	Main Function	Typical Level Setup	Applications
50	Live Sports 1	Mix Assist & Limit	NAB Broadcast	OB
51	Live Sports 2	Mix Assist & Limit	NAB Broadcast	OB
52	Gameshow 1	Mix Assist & Limit	NAB Broadcast	OB
53	Gameshow 2	Mix Assist & Limit	NAB Broadcast	OB
54	Talk 5Band	Voice Processor	NAB Broadcast	OB, PP

Presets for off-air Confidence Monitoring

No	Name	Main Function	Typical Level Setup	Applications
55	Mon NICAM	Monitor	EBU Broadcast	PP
56	Mon FM Stereo	Monitor	EBU Broadcast	PP
57	Mon FM Mono	Monitor	EBU Broadcast	PP
58	50us Converge	Emphasis pre-adjust	EBU Broadcast	BC, OB
59	75us Converge	Emphasis pre-adjust	EBU Broadcast	BC, OB

Presets for Special Effects

No	Name	Main Function	Typical Level Setup	Applications
60	Optical 35mm	Optical film sound emulate	Film Mastering	PP, MA
61	Optical 35mm-2	Optical film sound emulate	Film Mastering	PP, MA
62	Optical 16mm	Optical film sound emulate	Film Mastering	PP, MA
63	Optical 16mm-2	Optical film sound emulate	Film Mastering	PP, MA
64	Intercom	Voice Processor	NAB Broadcast	PP
65	Telephone	Voice Processor	NAB Broadcast	PP

Abbreviations

BC: Broadcast Continuity

CD: Mastering

DX: Digital Transmission & Link

OB: Outside Broadcast & Live Production

PP: Post Production

RO: Radio Studio Outlet

VE: Audio for Video Editing

Remote control FAQ

This section covers some of the most frequently asked questions regarding remote control of the DBMAX.

Q: What parameters can be set using serial remote control of the DBMax?

A: Preset change and Bypass using an RS485/422/232 controller.

Q: What serial protocol is used?

A: The serial protocol is 9600, N, 8, 1.
This means 9.6 kbaud, no parity, 8 bit, 1 stop.

Q: What is the command structure for the remote protocol?

A: #AA,CMD,VALUE<CR>

AA is Unit Address number as set on the Utility page.

CMD is command: PRE for preset change, BYP for Bypass.

VALUE is (RAM) preset number required, 0 for not bypassed, 1 for bypassed; <CR> is carriage return, the same as Enter or hex 0D.

Examples:

#05,PRE,10<CR> =Recall RAM preset no. 10 on DBMaxaddress 5.

#03,BYP,1<CR> =Bypass DBMaxaddress 3.

All commands and numbers are shown as ASCII. Presets should not include a "0" in front of low numbers.

Q: What ASCII characters should be sent for Recall of RAM preset no. 10 on DBMax address 5?

A: #05,PRE,10<CR> means these values (hex) actually transmitted: 23 30 35 2C 50 52 45 2C 31 30 0D

MASTER FADER

Why Make a Master Fader?

If a fade is performed before the DBMAX, the Compressor will try to increase the level as the fade decreases. To avoid this problem, fades must always be done after the DBMAX. The Master Fader makes it possible to perform a manual fade on the very Output of the DBMAX, enabling you to keep your fade in digital domain and ensuring perfect tracking of Left and Right.

Connecting and Calibrating the Master Fader

In order to work the Master Fader accurately, the DBMAX must be calibrated:

- Connect the Master Fader to the “External Controller” jack of the DBMAX.
- Press and hold the BYPASS key of the DBMAX while powering up.
- Scroll down to “Fader Calibration” using the MENU keys, and press the OK key.
- Move the Master Fader to maximum position. To compensate for mechanical tolerances draw back the Master Fader slightly.
- Press OK
- Move the Master Fader to minimum position. To compensate for mechanical tolerances draw back the Master Fader slightly.
- Press OK
- The Master Fader is now Calibrated. Turn power On/Off.

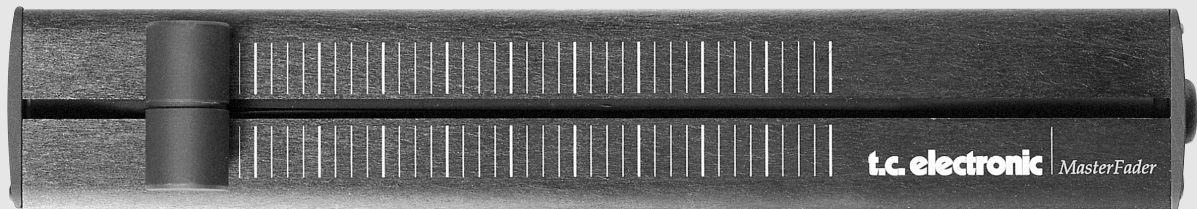

Activating the Master Fader

To activate the Master Fader, enter the Utility menu and scroll down to “Pedal Input Function” using the MENU keys. Dial the ADJUST wheel to choose “Ext. Fader”.

The Master Fader is now controlling the digital Fader of the DBMAX. The Fader located in the DBMAX Output section will now follow, and display the movement and the exact level of the Master Fader.

Cables and Lengths

The Master Fader uses standard mono jack cables. The cable can be extended using the jack to jack adapter, and can run at cable lengths up to 100 meters. Remember to recalibrate after extending the cable.