

Quick set up guide

Pixelline 1044 Issue 1.07 for software 1.07 issued July 2003

Please read the whole manual if you are unfamiliar with DMX based fixtures.

The following four pages are intended for people who are already fully experienced with dmx control of lighting fixtures.

Quick operating mode explanation

We have designed various operating modes developed to better harness the products functionality to provide you with multiple ways you can use the product to achieve the desired effect, with either DMX based controllers or through our video driven Pixeldrive package.

External control of all 54 channels on **DMX** This allows you to run the fitting with A full function desk. If you don't Have enough channels, you can reduce the Number by adjusting the resolution in the personality menu. You can control as little as 3 channels

Internal control of red green and blue **MAN** this function allows you to setup all cells Using the rgb internal control. You then Control the unit using the last menu (MAN)

No time to setup, but want the most Out of it? **Max 2** This mode gives access to just 10 channels of Control. The internal chase patterns, an RGB mix across all cells and a master intensity. Great if the shows the same day as the load in.

You have pre-production time to Program and want a unique set of Looks? **Max 1** As above, but you have individual control of All the cells as well as being able to control The internal chases because of the strobing Capabilities.

Earlier generation complex control **EX 61** This has been superceded with MAX 2 but Is retained for those familiar with this mode (Check out 'Mint' info in menu structure).

No desk, but you want control Of the internal chase patterns **EF M** User interface access to the internal patterns. You must set this mode up before you can Control the device from the PROGram menu.

Earlier generation chase pattern Control using 10 dmx channels **EF D** This has been superceded with MAX 1, but We kept it there for those of you already Familiar with the product.



Control tips

- Pressing the left hand MENU button acts as a reverse key and will take you back up the menu tree if you need to step back.
- MASTER/SLAVE mode as indicated to the right of the display, to control the unit normally set the device to slave. The master mode allows you to control the remaining products connected to a dmx line, without the use of a dmx external control. Master is not the default setup when leaving the factory.
- Remember that if you want the device to return to your setting you must press ENTER or upon power down/up the fitting will return to its previous setting.
- Remember that the PERSONALITY menu allows you to adjust the resolution or number of channels used in increments from 3 up to 54 that will explain if only as little as one cell is working when you are trying to control the entire row of cells.
- ***Important Channel 10 is the master intensity with MAX 2 and in EF D operating mode Channel 7 is master intensity.***
- You can switch the master intensity on or off from channel 55 when you use operating modes, EX61 or DMX, this allows older dmx desks to run in a better manner than before.

Operation tips

- The Pixeline is shipped with a pair of standard floor standing plates, however we also offer a yoke and a combined floor and yoke which makes it easier to setup the device, pack and transport. These are available at additional cost.
- We also have an access panel in the front of the unit, which allows you to slot in effect type gell diffusers as required. This will allow you to smooth, expand, stretch, split and vary the products standard 20 degree beam into a variety of different angles.
- Remember the load running through the Pixeline should not exceed 15 amps in total; please remember 4.34 amps per each 1000 watt circuit at 230 volts when planning your power and distribution requirements.
- Stroboscopic lighting in places of public entertainment requires you to inform the audience with suitable signage ahead of using the device.
- If the display disappears after a few minutes, just press the far left MENU button to switch it back on
- Because you may have rigged the unit in the air and cannot see the power and status indicators, there is an option in the personality menu to add a colour scroll on powering up the device to show the device has just been energized.
- This information relates to version 7 software, consult your dealer if you need an upgrade. Upgraded processors are sent out on an invoice which is credited when the old processors are returned as these can be re-programmed.
- **See next page for User Interface Menu Structure.**

ADDR		DMX address from 1-512 channels	
MODE	DMX	This gives you access to full external control without any extra functions	
	MAN	Provides access to control the RGB levels of all cells through the internal or manual control	
	EF D	Effects generator under DMX control via 10 channels (RGB mix at the end Overrides the generator, channel 7 is the chase master intensity).	
	EF M	Effects generator under internal control via the program function	
	EX 61	Individual control of all 54 channels with the effects generator control from channel 56 up to 61 cell master is 55 and chase master is 62	
	MAX 2	10 channel control, with the chase generator, combined master intensity and all cell control of red green and blue merged with the chase generators output	
	MAX 1	54 channel control of cells with a combined master intensity. The internal chase patterns are control from channels 55 upwards 61 is master intensity	
PERS	RES	Adjusts the number of channels needed to control the device, ideally you should have all 54 channels used, but on low channel projects, you can reduce the increments down from 54/27/18/9/6/3, internally patching adjacent cells	
	DISP	Display blanks if set to auto off (AOFF) status LED's remain illuminated	
	DINT	Display intensity, allows you to adjust the brightness of the display	
	RSET	Scrolls through colours at power on to show fitting is energized, you can switch this function on and off	
	DATA	Toggles between master and slave mode, do not switch to master if you plan to control the device with a DMX lighting desk	
	MINT	In normal DMX mode this adds a master intensity to the end of the number channel used, useful for older generation controllers Only works with in DMX mode and EX 61 operating mode	
MAN	RED	All cells controlled as red	
	GREEN	All cells controlled as green	
	BLUE	All cells controlled as blue	
PROG	LEVL	Master level of both chase one and two (0-255)	
	C1	EFF	Chase pattern select
		SPED	Chase speed
		XFAD	Adjusts from snap to cross fade between steps
	C2	EFF	Chase pattern select
		SPED	Chase speed
		XFAD	Adjusts from snap to cross fade between steps
	INFO	CPU	Main software version number
		DISP	Display controller software version

See appendix C for chase pattern description

Pixelline 1044 version 1.07 operating mode, channel layouts.

MAX 2 Low channel use mode, with combined master intensity and access to RGB colour
Mixing without cutting off the internal effects generator if activated

Ch1 All Red
Ch 2 All Green
Ch 3 All Blue
Ch 4 Chase 1 Effect (zero is generator turned off)
Ch 5 Chase 1 Speed
Ch 6 Chase 1 Xfade
Ch 7 Chase 2 Effect (zero is generator turned off)
Ch 8 Chase 2 Speed
Ch 9 Chase 2 Xfade
Ch 10 Combined master intensity (0-255)

MAX 1 Individual RGB cell control and use of internal effects generator, with a
Combined master intensity channel (ch 61)

Ch 1-54 RGB of all cells
Ch 55 Chase 1 Effect (zero is generator turned off)
Ch 56 Chase 1 Speed
Ch 57 Chase 1 Xfade
Ch 58 Chase 2 Effect (zero is generator turned off)
Ch 59 Chase 2 Speed
Ch 60 Chase 2 Xfade
Ch 61 Combined master intensity (0-255)

EF D The Internal dual effects generator under external DMX control with an rgb
mix which cuts off the internal effects generator if rgb is used.

Ch1 Chase 1 Effect (zero is generator turned off)
Ch2 Chase 1 Speed
Ch3 Chase 1 Xfade
Ch4 Chase 2 Effect (zero is generator turned off)
Ch5 Chase 2 Speed
Ch6 Chase 2 Xfade
Ch7 Master Intensity (0-255)
Ch8 All Red
Ch9 All Blue
Ch10 All Green

EX 61 Highest resolution control with separate master intensity for both cell RGB control and internal effects
generator. Option to switch on an off master intensity for cell RGB control (this function makes it easier to
work with older generation dmx control boards).

Having MINT (master intensity) turned in the personality menu, will add an extra channel. This gives you full control of all the cells and the effects generator.

Ch 1-54 RGB of all cells
Ch 55 Master intensity of all 18 cells RGB (not for internal chase generator)
Ch 56 Chase 1 Effect (zero is generator turned off)
Ch 57 Chase 1 Speed
Ch 58 Chase 1 Xfade
Ch 59 Chase 2 Effect (zero is generator turned off)
Ch 60 Chase 2 Speed
Ch 61 Chase 2 Xfade
Ch 62 Master intensity for the internal chase effects generator.



User Instructions issue 1.07 July 2003

Solid state lighting by James Thomas Engineering using silicon based light emitters.

You have purchased a product designed for a tough life on the road. We have thought about the life of this product, so that in the future you may wish to upgrade the six led boards only, in years to come as light emitting diodes become increasingly brighter.

Latest generation electronics and software ensure that this product will have a lifetime lasting years. We are one of the only companies specializing in a well designed heat management system. This system ensures that the led output does not deteriorate through heat induced degradation.

We have also designed the electronics to work within the specifications of the leds used. We do not overdrive the devices, nor are you able to. Overdriving the leds may increase the output, but this substantially reduces the lifetime of the leds. We want you to enjoy a truly 'plug and play' relationship with our range.

The Pixeline 1044 now has a family of accessories to make rigging and operation easier to handle. Combined floor and suspension brackets and flight case options are now offered and we will inform you of software upgrades if by registering this product serial number, owner and supplier details with us at; (productregistration@jamesthomas.co.uk).

We work closely with the major lighting console manufacturers to ensure that the latest personalities are available for you to gain the most from the product. The latest personalities are posted on our website at www.pixelpar.com

Energy conservation is a word seldom heard within the entertainment sector. By using this product you are doing your bit for the environment. With up to a 90% reduction in both heat and power consumed you can connect up to 22 units in a 16amp line and not worry about setting fire to surface being illuminated. Energy consumption is also proportionate to use how much you use the product, with 7 watts being the standby or blackout consumption and 165 watts if on full intensity.

The effects generator provides a range of the most common effects used. Our product features the ability to run two patterns at once. We have also included a colour mixing option (MAX1 and MAX2) giving you over 625 internal patterns and wash control. It is possible to use the lighting console to produce even more complex effects. With DMX data speeds being slower than our limitations, you are able to strobe the internal patterns a lot faster than from an external control source. Please remember to warn your audience if you use the strobe patterns.

We now offer pixeldrive as an option, giving you ultimate freedom to explore the true potential of multiple Pixelrange products. The Pixeldrive is offered in either mac or pc formats. Rather than thinking of the lights as fixtures, this package has been designed with IRAD systems RADLITE video manipulation engine, which turns the fixtures into pixels. With ethernet/ USB to dmx converters, up to 30 dmx universes are possible from one pixeldrive system.

We hope you enjoy the range of possibilities this product has to offer. Should you wish to suggest an improvement, then please do contact us at R&D@jamesthomas.co.uk.



Menu Access (See Menu Structure)

Overview

It is possible to set-up different operating modes by using the user interface (located top centre). This interface allows access to the different built in functions performed by the on-board microprocessor.

The four digit alpha numeric displays menu and function information. Four blue leds provide status information on power, data present, master and slave mode.

Pressing each of the four recessed switches located directly under the alphanumeric display performs access to the various functions.

Tip, The product is shipped, factory set to dmx address 001. The alphanumeric display fades out after 30 seconds, the display will illuminate when the menu key is pressed once.

Computer menus

- **To gain access to the following menu pages, press [menu] once, then use the up or down arrow to select the desired page.**
- **Once you have scrolled to the desired menu page, press [enter] once**
- **scroll to the desired sub menu and press [enter] once**
- **To adjust the function, use the up and down arrows, then press [enter] once**
- **Press [menu] once to return to your previous position**

Note 1) MASTER / SLAVE MODE - **IMPORTANT**

When the Pixelline 1044 is in SLAVE mode, the unit receives and processes DMX data for its control. This mode would be used in normal operation.

When in MASTER mode, the Pixelline 1044 acts as a controller and transmits the 54 channels of DMX data generated by the internal effects generator. In this mode, one Pixelline 1044 can be used to synchronize other 1044s connected to the same DMX data cable.

The standard DMX protocol is used for the data transmission so other lighting products using this control protocol can be driven by a Pixelline 1044 in Master mode.

When a Pixelline 1044 is running in master mode, ensure that no other controller (or other 1044 in master mode) is connected to the data line otherwise data corruption will occur.

DMX transmission from the Pixelline1044 only occurs, when the menu of the user interface is at the top of the tree, ie showing the DMX start address Axxx. When the menu system is entered to change operating parameters, DMX transmission ceases. The "Master" 1044 will work in real-time so the desired effect can be selected using the user interface with the LEDs of the master unit showing the desired effect. Once this is achieved, taking the menu back to the top will initiate DMX transmission and other lighting units connected to the data line will follow the Master unit.



Data connection

The Pixelline 1044 is fitted with a 5 pin male and female xlr connector, located at each end of the unit, within the recessed mains and data cable entry chamber. This product is capable of receiving USITT DMX512. Wiring code is listed below.

Pin 1	Ground	Pin 2	Data - input
Pin 3	Data + input	Pin 4	not used
Pin 5	not used		

Electrical information

Input voltage	100 volts to 250 volts
Power consumption	standby power 7 watts Maximum power 165 watts
Power inlet	16 amp 240 volt 2 pin and earth chassis Male with chassis Female located at either end of the product, in a recessed cable entry chamber
Fuse	Anti-surge (T) 2 amp 20mm HBC S505 Series ceramic body (RS 265-1212)

Mechanical information

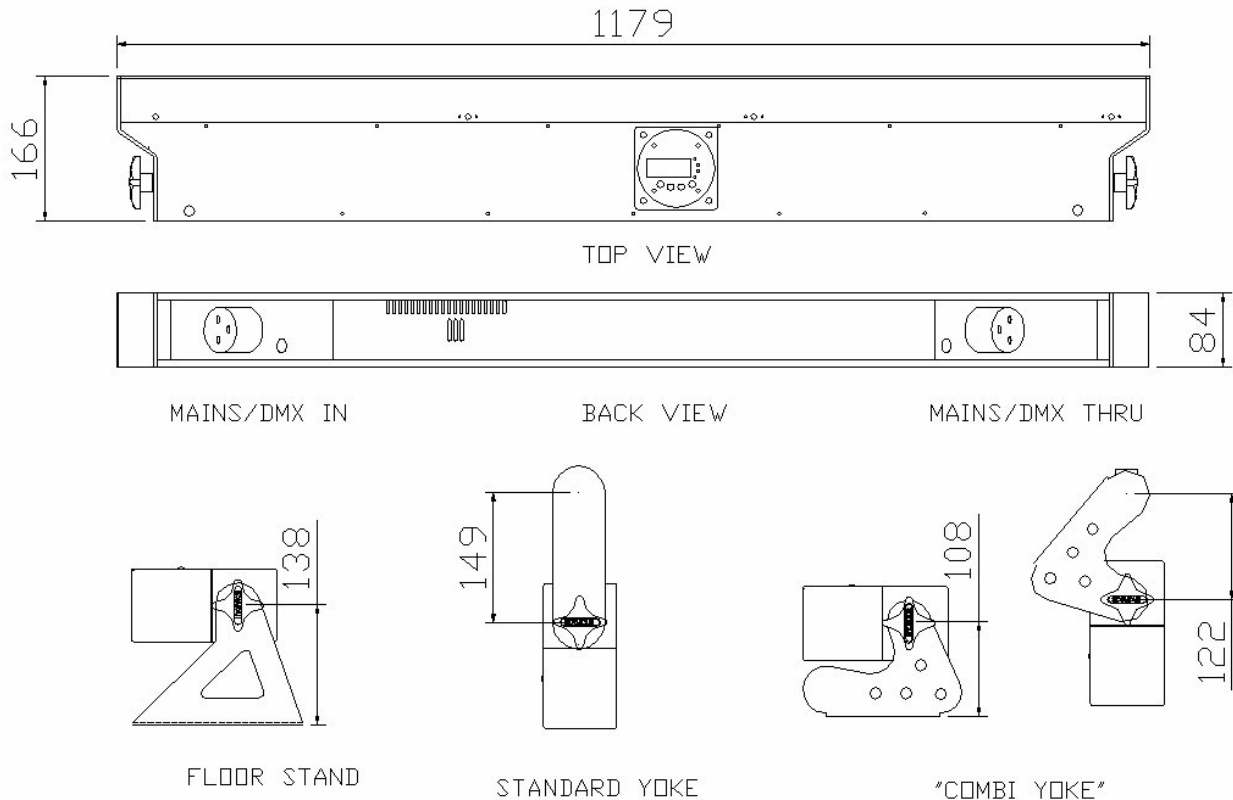

Weight	11 Kg
IP Rating	IP20
Paint finish	Epoxy polyester powder coat (other colours by request)
Paint colour	Black standard. White, Polished or anodised aluminium available to order.
Floor stands	1 pair supplied per unit
Yoke (SS1044Y)	Option available at additional cost
Combi Yoke (SS1044CY)	Allows floor and truss mounting of batten. Option available at additional cost.

Appendix A

Useful colour dmx values for recognised colour filters

Reference number	name	BLUE DMX value	RED DMX value	GREEN DMX value
2	rose pink	34	255	52
16	Medium bast. Amber	16	255	101
7	pale yellow	18	255	142
8	dark salmon	0	131	23
10	medium yellow	0	255	139
13	straw tint	7	211	98
15	deep straw	0	255	95
17	surprise peach	4	184	53
19	fire red	0	114	60
20	medium amber	0	175	60
21	golden amber	0	165	38
22	dark amber	0	170	26
24	scarlet	0	44	3
25	sunset red	0	69	10
26	bright red	0	44	1
36	medium pink	8	99	27
39	pink carnation	8	75	27
46	dark magenta	2	42	2
48	rose purple	18	63	9
52	light amber	5	18	8
58	lavender	23	25	3
68	sky blue	15	4	10
71	tokyo blue	4	2	0
75	evening blue	10	0	3
79	just blue	10	1	3
88	lime green	0	58	46
90	dark yellow green	0	0	13
100	spring yellow	0	110	65
105	orange	0	160	42
106	primary red	0	46	0
113	magenta	1	56	0
115	peacock blue	10	13	34
116	medium blue green	7	0	22
118	light blue	8	0	13
119	dark blue	12	0	0
120	deep blue	7	1	0
121	lee green	0	38	40
122	fern green	0	31	48
124	dark green	0	0	35
126	mauve	8	28	0

Reference number	name	BLUE DMX value	RED DMX value	GREEN DMX value
127	smoky pink	2	25	5
128	bright pink	8	64	0
131	marine blue	13	27	48
132	medium blue	15	0	8
134	golden amber	0	83	26
135	deep golden amber	0	64	7
138	pale green	2	34	26
139	primary green	0	2	17
140	summer blue	9	16	21
141	bright blue	12	0	15
142	pale violet	11	28	15
143	pale navy blue	7	9	13
148	bright rose	2	49	3
158	deep orange	0	101	19
161	slate blue	11	17	16
162	bastard amber	5	52	23
164	flame red	0	37	3
165	daylight blue	10	6	11
166	pale red	2	55	8
170	deep lavender	4	21	8
172	lagoon blue	8	0	15
174	dark steel blue	4	9	8
176	loving amber	2	32	10
179	chrome orange	0	33	12
180	dark lavender	7	7	2
181	congo blue	2	1	0
182	light red	0	22	1
183	moonlight blue	3	0	5
192	flesh pink	3	29	6
193	rosy amber	2	31	6
194	surprise pink	4	16	6
195	zenith blue	6	0	0
196	true blue	5	5	8
197	alice blue	6	4	4
198	palace blue	2	0	0
200	double ct blue	4	3	3
201	full ct blue	4	9	7
202	half ct blue	4	17	11
219	florescent green	5	14	20
322	soft green	5	9	29
323	jade	4	2	21
325	mallard green	1	0	6

Reference number	Name	BLUE DMX value	RED DMX value	GREEN DMX value
327	forest green	0	0	4
328	follies green	9	64	4
332	special rose pink	4	49	1
341	plum	4	36	12
343	special med. Lavender	8	6	0
344	violet	12	19	10
352	glacier blue	7	3	12
353	lighter blue	11	15	27
354	special steel blue	9	6	30
363	special medium blue	11	0	0
366	cornflour	10	13	13
151	gold tint	6	95	41
152	pale gold	7	102	41
153	pale salmon	9	105	43
154	pale rose	9	104	48
109	pale salmon	9	144	48
108	english rose	5	164	57
107	light rose	9	161	48
110	middle rose	10	119	40
111	dark pink	10	139	27
144	no colour blue	12	53	45
117	steel blue	17	14	38
147	apricot	3	120	43
102	light amber	0	107	55
103	straw	10	157	83
104	deep amber	0	206	94
101	yellow	0	177	105
63	pale blue	9	39	31

Appendix B.

Pixel Line Effects Generator (Version 1.07 Software)

DMX Value	Effect
0-7	OFF
8-15	Primary/secondary 1 cell per colour Rainbow forward
16-23	Primary/secondary 1 cell per colour Rainbow reverse
24-31	White 1 cell blip forward
32-39	White 1 cell blip reverse
40-47	Double bouncing 1 cell white blip from centre to outer edge
48-55	50/50 duty cycle strobe White
56-63	50/50 duty cycle strobe Red
64-71	50/50 duty cycle strobe Blue
72-79	50/50 duty cycle strobe Yellow
80-87	50/50 duty cycle strobe Green
88-95	Pulse strobe White
96-103	Pulse strobe Blue
104-111	Rainbow strobe
112-119	RGB strobe
120-127	Primary / secondary chase
128-135	RGB Chase
136-143	Yellow / Blue chase
144-151	7 Colour roll
152-159	Yellow / Blue alternate cells
160-167	Red / Blue alternate cells
168-175	Miscellaneous chase 1
176-183	Miscellaneous chase 2
184-191	Miscellaneous chase 3
192-199	Miscellaneous chase 4
200-207	OFF
208-215	OFF
216-223	OFF
224-231	OFF
232-239	Static Red
240-247	Static Green
248-255	Static Blue

James Thomas Engineering Ltd,
Navigation Complex,
Navigation Road,
Diglis Trading Estate,
Worcester.
WR5 3DE.
United Kingdom.

Telephone +44 (0)1905 363 600
Facsimile +44 (0)1905 363 601
e-mail info@jamesthomas.co.uk
websites www.pixelpar.com
www.jamesthomas.co.uk

The information contained in this document may be subject to change without notice. The latest update is posted on the website.

James Thomas Engineering Limited makes no warranty of any kind with regard to this material, including but not limited to, the implied warranties of fitness for a particular purpose.

James Thomas Engineering Limited shall not be liable for errors contained herein or for incidental or consequential damages in connection with the furnishing, performance or use of this material. All trademarks are acknowledged.

All brand or product names are trademarks or registered trademarks of their respective owners

