

C6/C690

Data Sheet

Safety precautions

Never stand in the immediate vicinity of loudspeakers driven at a high level. Professional loudspeaker systems are capable of causing a sound pressure level detrimental to human health. Seemingly non-critical sound levels (from approx. 95 dB SPL) can cause hearing damage if people are exposed to it over a long period.

In order to prevent accidents when deploying loudspeakers on the ground or when flown, please take note of the following:

When setting up the loudspeakers or loudspeaker stands, make sure they are standing on a firm surface. If you place several systems on top of one another, use straps to secure them against movement.

Only use accessories which have been tested and approved by d&b for assembly and mobile deployment. Pay attention to the correct application and maximum loading capacity of the accessories as specified in our "Rigging accessories" manual.

Ensure that all additional hardware, fixings and fasteners used for installation or mobile deployment are of an appropriate size and load safety factor. Pay attention to the manufacturers instructions and to the relevant safety guidelines.

Regularly check the loudspeaker housings and accessories for visible signs of wear and tear, and replace them when necessary.

Regularly check all load bearing bolts in the mounting devices.

Loudspeakers produce a static magnetic field even if they are not connected or are not in use. Therefore make sure when erecting and transporting loudspeakers that they are nowhere near equipment and objects which may be impaired or damaged by an external magnetic field. Generally speaking, a distance of 0.5 m (1.5 ft) from magnetic data carriers (floppy disks, audio and video tapes, bank cards, etc.) is sufficient; a distance of more than 1 m (3 ft) may be necessary with computer and video monitors.

WARNING!

CAUTION!

General Information

C6 Data Sheet

Version 2.0E, 05/2001, D2077.E.02

© by d&b audiotechnik AG 2001; all rights reserved.

The information presented in this document is, to the best of our knowledge, correct. We will however not be held responsible for the consequences of any errors or omissions.

Technical specifications, weights and dimensions should always be confirmed with d&b audiotechnik AG prior to inclusion in any additional documentation.

d&b audiotechnik AG

Eugen-Adolff-Strasse 134, D-71522 Backnang

Telephone +49-7191-9669-0, Fax +49-7191-95 00 00

C6

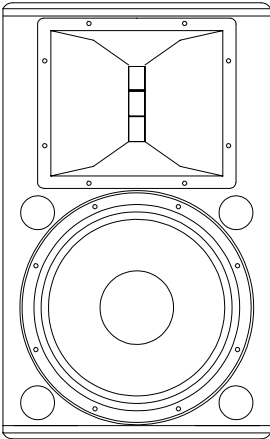

The C6 cabinet is a full range, two way bass-reflex enclosure fitted with a 12" LF driver passively connected to a 2" HF compression driver which is coupled to a 60° x 40° CD horn.

The C6 cabinet is constructed from marine plywood and has an impact resistant paint finish. The front of the loudspeaker cabinet is fitted with a rigid metal grill covered with a replaceable acoustically transparent foam. The cabinet top plate has an integral handle and four M10 threaded inserts for mounting brackets and rigging. The L shaped metal plate at the bottom of the cabinet also incorporates a handle, four M10 threaded inserts, a socket to accept a loudspeaker stand and, on the rear panel, two parallel wired Speakon-NL4 or EP-5 connectors.

The C6 frequency response covers a 70 Hz to 17 kHz band - quite sufficient for applications that don't require deep bass. However, for high level music reproduction, the C6 benefits from the bass extension and added power of active subwoofer systems E18-SUB, C4-SUB or C7-SUB.

The outstanding performance features of the C6 are its narrow dispersion angle and its very high output capability - these features are best used for audience coverage at distances to 20 m (65 ft) and beyond. Within a larger system C6 loudspeakers are ideal as high power delay systems and for high intelligibility speech reinforcement. The precisely angled rear side panels of the cabinet allow C6s to be simply placed side by side forming a powerful array with accurate 60° horizontal coverage per loudspeaker. To simplify array construction an extensive range of mounting and rigging accessories is available - please refer to the C6/C7 brochure.

CAUTION!

Only operate C6 loudspeakers with a d&b P1200A mainframe fitted with C6 controller modules or a d&b E-PAC (version 2) in C6 configuration, otherwise there is a risk of damaging the loudspeaker components.

Version C690

The C690 has wider horizontal and vertical dispersion than the C6, the only difference being the 90° X 50° CD horn. C690 is driven by the same controller as the C6 and is suited to near field applications where wider coverage at high SPLs is required.

Connections

The C6 cabinet is fitted with a pair of Speakon-NL4 connectors. All four pins of both connectors are wired in parallel. The C6 uses the pin assignments 1+/1-. Pins 2+/2- are designated to C and E-Series active subwoofers. Using one connector as the input, the second connector allows for direct connection to additional loudspeakers.

The C6 can be supplied with EP-5 output connectors as an option. Pin equivalents of Speakon-NL4 and EP-5 connectors are listed in the table on the left.

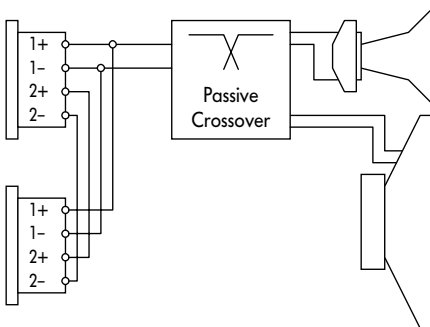

Connector wiring

EP-5	1	2	3	4	5
NL4	1+	1-	2+	2-	n.c.

Speakon- NL4 and EP-5 pin assignments

Operation with P1200A

Up to two C6 loudspeakers can be driven by each P1200A power amplifier channel. Fitting one C6-CO and one subwoofer controller module allows a single mainframe to drive two C6 and two active subwoofer cabinets (E18-SUB, C4-SUB or C7-SUB). All cabinets can be linked together locally and fed by a single four-wire cable from either mainframe output connector.

C6 controller module switches

Standard setting

If the CUT switch and MON switch are not selected the module is configured for use with C6 loudspeakers used as a stand alone system without subwoofers.

CUT switch and indicator

Set to CUT, a high pass filter with a 110 Hz cut-off frequency is inserted in the controller signal path. The yellow CUT LED illuminates. The C6 system is now configured for use with d&b C-Series active subwoofers.

MON switch and indicator

If the MON switch is selected the yellow MON LED illuminates and the low frequency level is reduced by 3 dB. This setting particularly applies to the C6-MON as this setting reduces the low frequency energy gained from the coupling effect of floor placement.

160Hz setting (CUT and MON switches both selected)

If the 160Hz mode is selected, a high pass filter is inserted in the controller signal path. The crossover frequency of 160 Hz is higher than in CUT mode and thus increases the available headroom in the C6 system. The 160Hz mode can be selected when the system is operated with d&b subwoofers C4-SUB, C7-SUB or E18-SUB (also in 160Hz mode, see manual section E18-SUB). This configuration is particularly useful when C6 loudspeakers are stacked directly on top of the subwoofer system.

Operation with E-PAC

To drive C6 cabinets the E-PAC has to be configured to C6 mode.

For an E-PAC version 2, the configuration is selected by setting the appropriate DIP switches on the rear panel.

For an E-PAC version 3, the configuration is set via a front panel digital rotary encoder in conjunction with an LCD.

The CUT and HFA settings are available on versions 2 and 3. The characteristics of the CUT setting are explained on the previous page under the section "C6 controller module switches".

The functions MON and 160 Hz are not available with the E-PAC controller.

The E-PAC can drive a single C6 cabinet at an output power of 300 watts. LO IMP mode allows the E-PAC to drive two C6 cabinets with a 6 dB reduction of input level to the speakers.

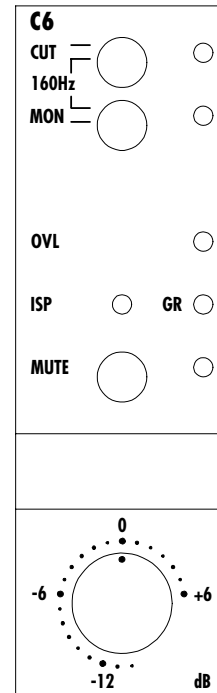

Controls on C6 controller module

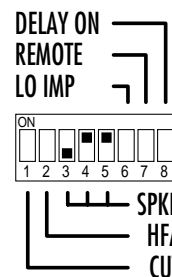

E-PAC Configuration for C6 (E-PAC version 2)

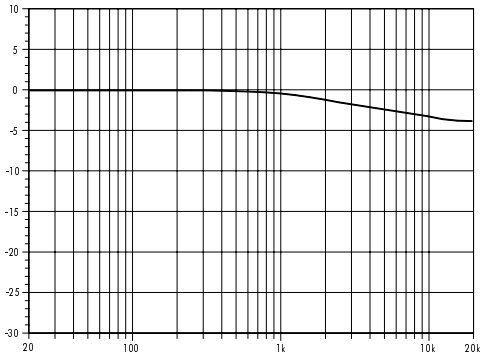

Frequency response correction of HFA circuit (only available with E-PAC)

HFA setting

In HFA mode (High Frequency Attenuation), the HF response of the C6 system is rolled off. The HFA circuit configures the C6 loudspeakers to provide a natural, balanced frequency response when a unit is placed close to listeners in near field or delay use.

High Frequency Attenuation begins gradually at 1 kHz, dropping by approximately 3 dB at 10 kHz. This roll-off mimics the decline in frequency response experienced when listening to a system from a distance in a typically reverberant room or auditorium.

Dispersion characteristics

The diagrams below show dispersion angle vs frequency plotted using lines of equal sound pressure (isobars) at -6 dB and -12 dB. The nominal 60° horizontal dispersion is maintained from 20 kHz down to 2 kHz.

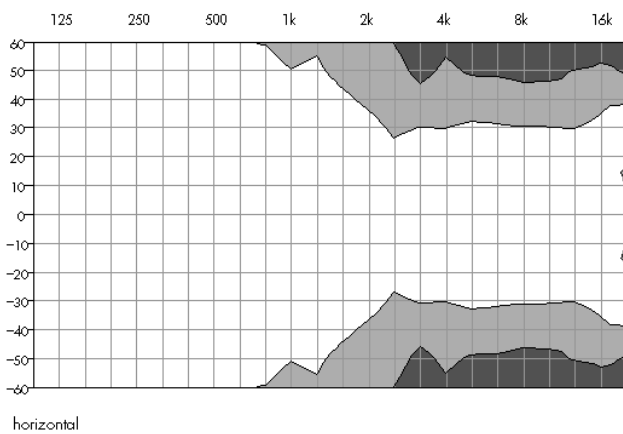

C6 Isobar diagram

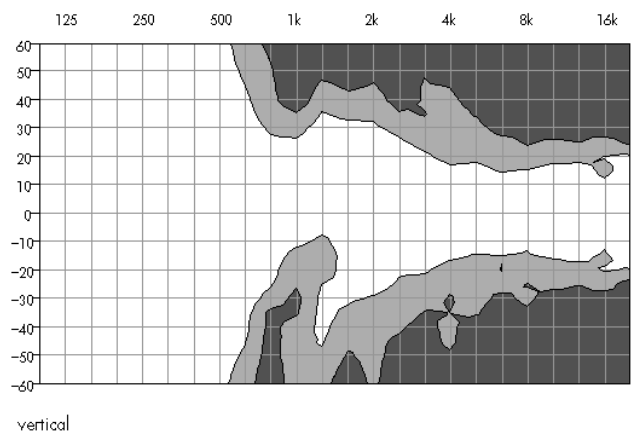

Technical specifications

C6 (C690) system data

Frequency response (-5 dB)	70 Hz ... 17 kHz
Max. sound pressure (1 m, free field) with P1200A	133 (132) dB
Max. sound pressure (1 m, free field) with E-PAC	131 (130) dB
(SPLmax peak, pink noise test signal with crest factor of 4)	
Input level (SPLmax)	+16 dBu
Input level (100 dB-SPL / 1 m)	-14 (-13) dBu
Polarity to controller INPUT (XLR pin 2: + / 3: -)	LF: + / HF: -

C6 (C690) loudspeaker

Nominal impedance	8 ohms
Power handling capacity (RMS / peak 10 ms)	200 / 800 W
Nominal dispersion angle (hor. x vert.)	60° x 40° (90° x 50°)
Connections	2 x Speakon-NL4
.....	(optional 2 x EP-5)
Pin assignments	1+ / 1-
.....	(EP-5: 1 / 2)
Weight	28 kg (62 lb)

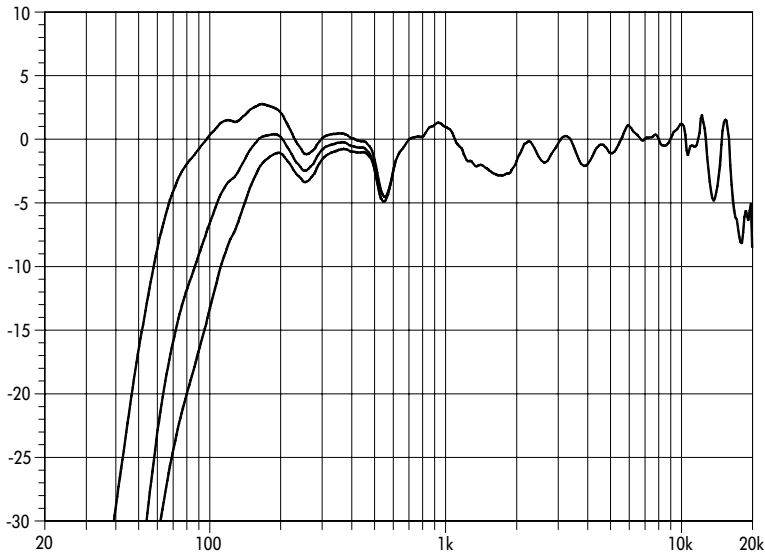

C6 frequency response, standard, CUT and 160Hz switch settings

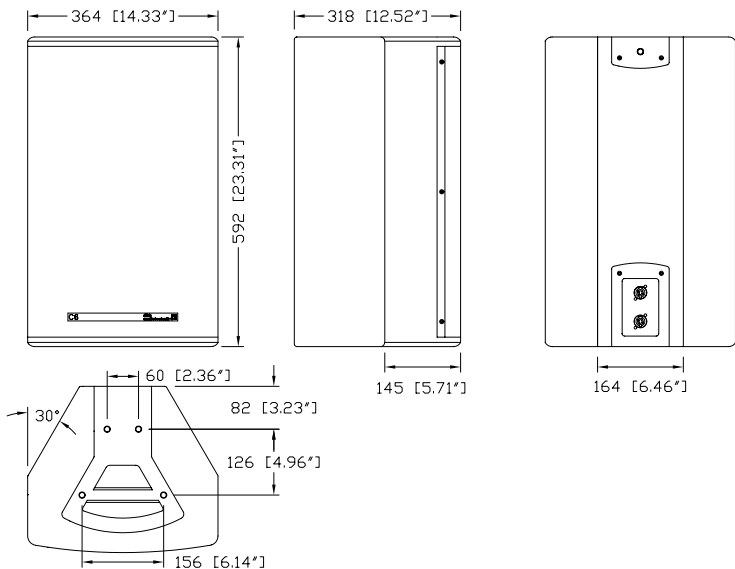

C6 cabinet dimensions mm [inch]

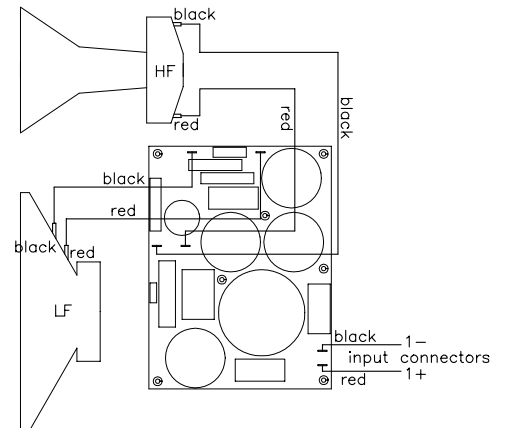

C6 wiring diagram

